

55th joint meeting of the CIDOC CRM SIG and ISO/TC46/SC4/WG9; 48th
meeting of FRBR/LRMoo SIG

6-9 December 2022

Luxembourg Centre for Contemporary and Digital History (C2DH),
University of Luxembourg

Maison des Sciences Humaines 11, Porte des Sciences L-4366 Esch-sur-Alzette

Participants

Aleka Seliniotaki (ICS-FORTH, GRC); **Alessia Vaccariello** (Sapienza University of Rome, ITA); **Anais Guillem** (LRMH/MAP-CNRS, FRA); **Annick Stein** (BnL, LUX); **Antoine Jeusette** (CNA, LUX); **Athina Kritsotaki** (ICS-FORTH, GRC); **Carlo Blum** (BnL, LUX); **Carmen Noguera** (UniLu, LUX); **Christian-Emil Ore** (University of Oslo, NOR); **Chryssoula Bekiari** (ICS-FORTH, GRC); **Chtistel Kayser** (BnL, LUX); **Donatella Fiorani** (Sapienza University of Rome, ITA); **Edurne Kugeler** (MNHA, LUX); **Eleni Tsouloucha** (ICS-FORTH, GRC); **Elias Tzortzakakis** (ICS-FORTH, GRC); **Elisabetta Bellot** (MPI: Luxembourg, LUX); **Erin Canning** (LINCS, CAN); **Esther Sánchez Coro** (MPI: Luxembourg, LUX); **Francesco Beretta** (LARHRA, FRA); **George Bruseker** (Takin.solutions, BGR); **Igor Bajena** (Hochschule Mainz, DEU / University of Bologna, ITA); **Inês Koch** (FEUP/INESC TEC, PRT); **Jessica Ye** (LINCS, CAN); **Maja Žumer** (University of Ljubljana, SVN); **Maliheh Dorkhosh** (Central Library and Documentation of Center - University of Tehran, IRN); **Maria Birukov** (UniLu, LUX); **Mark Fichtner** (Germanisches Nationalmuseum Nuremberg, DEU); **Markos Katsianis** (University of Patras, GRC); **Marta Acierno** (Sapienza University of Rome, ITA); **Martin Doerr** (ICS-FORTH, GRC); **Martina Febra** (MPI: Luxembourg, LUX); **Massoomeh Niknia** (Kharazmi University, IRN); **Mélanie Roche** (BNF, FRA); **Michelle Pfeiffer** (INRA, LUX); **Muriel van Ruymbeke** (C2DH-UniLu, LUX); **Nils Geißler** (CCeH, University of Cologne, DEU); **Nina Janz** (UniLu, LUX); **Otilia Tira** (INPA, LUX); **Pat Riva** (Concordia University of Canada, CAN); **Pavlos Fafalios** (ICS-FORTH, GRC); **Philippe Michon** (CHIN, CAN); **Piotr Kuroczyński** (Hochschule Mainz, DEU); **Puyu Wang** (University of Oxford, GBR); **Raphaëlle Krummeich** (Université de Rouen, FRA); **Robert Sanderson** (Yale University, USA); **Robert Nasarek** (Germanisches Nationalmuseum Nuremberg, DEU); **Roland Billen** (University of Liege, BEL); **Sonia Beaumont** (MPI: Luxembourg, LUX); **Stephen Stead** (Paverprime Ltd, GBR); **Thanasis Velios** (University of Arts London, GBR); **Tiantian Wang** (UniLu, LUX); **Trond Aalberg** (OsloMet, NOR); **Vincent Alamercery** (LARHRA, FRA); **Wolfgang Schmidle** (DAI, DEU)

Contents

55 th joint meeting of the CIDOC CRM SIG and ISO/TC46/SC4/WG9; 48 th meeting of FRBR/LRMoo SIG.....	1
6-9 December 2022.....	1
Luxembourg Centre for Contemporary and Digital History (C2DH), University of Luxembourg.....	1
Maison des Sciences Humaines 11, Porte des Sciences L-4366 Esch-sur-Alzette	1
Participants	1
Tuesday 6 December 2022	5
Issue 599: Editorial Statuses of the CRMbase and family models	5
[NEW ISSUE]: “Official” status for FRBR/LRMoo.....	5
[NEW ISSUE]: explicitly document cross-references btw family models.....	5
Issue 596: Supplementary documentation	6
[NEW ISSUE]: Update the modelling constructs found under The Model\Use&Learn\Functional Overview.	8
Issue 494: Scope-note guidelines.....	8
[NEW ISSUE]: Pending revisions on the Scope-note writing guidelines	8
Issue 568: Incorporate changes in the model implemented by the ISO group to the versioning pipeline of the SIG.....	8
Issue 603: Contextualize issues in a more informative way	9
Reschedule the 57 th CIDOC CRM SIG, 50 th FRBR/LRMoo SIG & ISO/TC46/SC4/WG9 Meeting.....	9
Issue 563: Adoption and governance	10
Translation methods observed by different initiatives –open discussion among representatives of official translation teams.	10
Wednesday 7 December 2022.....	11
Issue 364: Create Profile Markup Language/Schema/ Ontology Profiles.....	11
Issue 588: Common Policy / Method for Implementing the .1 Properties of Base and Extensions in RDF	11
Erlangen OWL and CRM RDF. Steps towards CRM OWL (Presentation by Mark Fichtner).....	13
Issue 615: scope note of E13 Attribute Assignment	13
[NEW ISSUE]: Redraft the scope note of P38 deassigned.....	14
[NEW ISSUE]: reclassifying species – implications for E17 Type Assignment	14
Issue 476: Pxxx represents entity of type	14
Issue 610: Deprecate Typed Properties in CIDOC CRM?	15
[NEW ISSUE]: Are there TPs among the CRM inverse properties?	16
[NEW ISSUE]: Inheritance of strong and weak shortcuts	16

Issue 622: Redraft & update intro to CRMarchaeo	17
Issue 621: Update synchronization btw CRMarchaeo and CRMbase.....	17
Issue 584: AP32 discarded into (scope note refinement).....	18
Issue 549: revise TX5 Reading vs TX6 Transcription	19
Issue 556: Content of the minimal vocabularies for restricting the CIDOC CRM Types	20
Issue 608: New examples for P161 <i>has spatial projection</i>	20
Issue 492: Spatiotemporal formalization about the presence of parts.....	21
Issue 617: Is $P7(x,y) \wedge P89(y,z) \Rightarrow P7(x,z)$ still regarded as true?.....	22
Issue 616: shortcuts in P50 has current keeper, P52 has current owner, P55 has current location ..	22
[NEW ISSUE]: What is required for expressing current knowledge?.....	23
Issue 613: Inverse shortcuts	23
Thursday 8 December 2022	24
Issue 620: Temporal proximity of events for O13 triggers	24
Issue 612: Diagrams for Position Measurement and properties in the introduction of CRMsci.....	25
Issue 611: Scope notes for the properties of Position Measurement	25
Issue 623: Editorial check of CRMsci examples	26
EPISA – Entity and Property Inference for Semantic Archives.....	32
Issue 364: Create Profile Markup Language/Schema/ Ontology Profiles (continuation).....	32
Issue 351: Modelling Principles.....	32
587 WD: Principles for Modelling Ontologies: A short reference guide (intro and examples)	33
Issue 533: How to disambiguate polysemous concepts used as ontological classes	34
Issue 601: publish research questions on the website	34
Issue 624: Add E33_E41_Linguistic_Appellation to the Official Specification.....	35
Issue 594: Semantically replacing Recording Event and Externalization Event.....	36
Issue 547: CRMdig update	36
Friday 9 December 2022	40
Issue 482: CIDOC CRM interfacing risk assessment in conservation	40
Issue 488: Modelling an Actor carrying out an action at the Behest of Another	41
Issue 557: Which family model should classes (i) Provision and (ii) Business Obligation appear under?	41
Issue 481: scope notes for socP21 and socP22.....	42
Reschedule the 57 th CIDOC CRM SIG, 50 th FRBR/LRMoo SIG & ISO/TC46/SC4/WG9 Meeting.....	42
Issue 623: Editorial check of CRMsci examples (continuation)	43

Issue 549: revise TX5 Reading versus TX6 Transcription	45
APPENDICES	49
Appendix I – List of abbreviated names.....	49
Appendix II -Issues	49
588	49
584:	50
556	51
613:	52
620:	53
612:	54
611:	55
623:	58
624:	60
594:	60
482:	61
549:	61

Tuesday 6 December 2022

Issue 599: Editorial Statuses of the CRMbase and family models

The issue has been previously closed (upon deciding on the labels and definitions for the metadata and values collected for statuses of CRMbase and family model versions) but there was still a need for the SIG to review how the previous decisions have been implemented.

ETs presented the implementation of the updated editorial statuses on the CIDOC CRM site.

- The Versions of the CIDOC CRM tab now looks like [that](#). All columns come with short definitions on the top part of the page.
- The versions for extensions of the CRM have been also updated. They can be found under their respective model. For instance, the tab for CRMarchaeo versions looks like [that](#), and the one for FRBR/LRMoo looks like [that](#).

Discussion points:

- FRBRoo Version 2.4 is as official as it gets and should be labelled “Official”. However, given that IFLA does not submit documents to ISO, the current definitions for Official used for CIDOC CRM cannot be applied to FRBRoo.
 - **Decision:** Start a [new issue](#) about the reformulation of the definition for “Official” status, to cover FRBR/LRMoo.
- There are dependencies between family models themselves: (CRMarchaeo, CRMsci), (CRMinf, CRMsci), (CRMtex, CRMinf), (CRMba, CRMarchaeo), (CRMba, CRMsci) that are not declared in the version information (or in the specification documents). This information should be easily accessible. However, this information is not always known. To avoid using together incompatible versions of said models, editors of a CRM extension should add explicit cross-references to other models.
 - **Decision:** ETs to contact CRM-family model maintainers and collect explicit cross-references to other models, where they are missing. This is to be reported through a new issue.

[NEW ISSUE]: “Official” status for FRBR/LRMoo

The SIG appointed MR to provide a definition for the Official status of FRBR/LRMoo that does not explicitly refer to ISO submission (since this is not the process with IFLA). IFLA acts on delegation by ISO, so a version that has been approved by IFLA is as official as it gets.

HW: MR

[NEW ISSUE]: explicitly document cross-references btw family models

There are dependencies between family models themselves: (CRMarchaeo, CRMsci), (CRMinf, CRMsci), (CRMtex, CRMinf), (CRMba, CRMarchaeo), (CRMba, CRMsci) that are not declared in the version information (or in the specification documents). This information should be easily accessible. However, this information is not always known. To avoid using together incompatible versions of said models, editors of a CRM extension should add explicit cross-references to other models.

- **Decision:** ETs to contact CRM-family model maintainers and collect explicit cross-references to other models, where they are missing. This is to be reported through a new issue (current).

- **Proposal:** add a column in CRMfamily models versions labelled “Other dependencies”, where to list all necessary relevant information. FORTH to implement this and the SIG will give an opinion.

Issue 596: Supplementary documentation

The issue has been previously closed (upon agreeing where each document should appear on the site) but there was still a need for the SIG to review how the previous decisions have been implemented.

ETs presented the appropriate link on the site, where each document will appear under. Specifically:

- Path: [Resources\Guidelines & Templates\Templates](#)
 - [Template for family models](#)
 - [Template for examples in the definition documents of the CRMbase and the CRM extensions](#)
 - [Guidelines for writing scope-notes](#)
- Path: [Resources\Guidelines & Templates\ Assisting Translations](#)
 - [CIDOC CRM Translation Order](#)
 - [CIDOC CRM Translation Best Practices](#)
 - [Governance Guidelines \(first draft sketch\)](#)
- Path: [Home\Editorial Suggestions](#)
 - Small Edits Checklist –[submission form](#)
 - [Response Sheet](#) (anonymized)
- Path: [Resources\Versions of the CIDOC-CRM\ \(version No.\)](#) (here for version 7.1.2):
 - see column “Encodings” for the
 - [.1 Properties table](#) (HTML page)
 - [Properties with the same domain and range class](#) (HTML page)
 - See column “Available Documents” for the:
 - .zip file of the Figures used in the version in an editable form (where available – i.e., V7.1.1 going forward)
 - Data examples for the versions that have them –namely:
 - [V6.2.1](#): rdfs/ttl (Winckelmann graphs)
 - [V5.0.1](#): html/docx/pdf/rdfs (Benaki Epitaphios)
 - [V4.2](#): html/docx/pdf/rdfs (Benaki Epitaphios)
- Path: [Community\Activity Documentation](#) for Project and WG Documentation

Proposal by FORTH up for discussion: Figures and data examples should not appear under “Available Documents” because they do not stand as the specification document of CIDOC CRM. Instead they should appear as follows:

- **Figures:** within the relevant version in a separate section with shortcut to new link: path **Resources\Figures and Diagrams\Figures**

Version	Release Date	Available Documents	Encodings	Status
Version 7.2.2	October 2022	CIDOC CRM v7.2.2.pdf, CIDOC CRM v7.2.2.docx		Draft
Version 7.2.1	June 2022	v7.2.1.docx, v7.2.1.pdf		Draft
Version 7.1.2	June 2022	.docx, .pdf	-RDFS (main, pc, suppl., more) -JSON-LD Context -XML -Classes & Properties declarations -Classes & Properties Translations & Versioning	Official (Base for initial ISO submission)

Volume A:
Definition of the CIDOC Conceptual Reference Model

Produced by the CIDOC CRM Special Interest Group

Version 7.2.2
September 2022

Editors: Chryssoula Bekiarı, George Bruseker, Erin Canning, Martin Doerr, Philippe Michon, Christian-Emil Ore, Stephen Stead, Athanasios Vellos

CC BY 4.0 2022 Individual Contributors to CIDOC CRM 7.2.1

Release Date : October 2022
Current main editors: Chryssoula Bekiarı, George Bruseker, Erin Canning, Martin Doerr, Philippe Michon, Christian-Emil Ore, Stephen Stead, Athanasios Vellos.
Contributors: Individual Contributors to CIDOC CRM 7.2.2.
Status: Closed

Available Documents:
 CIDOC CRM v7.2.2.pdf CIDOC CRM v7.2.2.docx Figures (.zip file)

Available Documents:
 CIDOC CRM v7.2.2.pdf CIDOC CRM v7.2.2.docx

Figures:
 Figures (.zip file)

- **Diagrams:** within the relevant version in a separate section with shortcut to new link: path **Resources\Data Examples**

Version 6.2.1	October 2015	(.pdf), (.docx)	-RDFS (main) -XML -Classes & Properties declarations -Classes & Properties Translations & Versioning	Stable	Produced by the ICOM/CIDOC Documentation Standards Group, continued by the CIDOC CRM Special Interest Group
Version 4.2	June 2005	(.pdf), (.doc), Russian translation	-XML -Classes & Properties declarations -Classes & Properties Translations & Versioning	Stable	Version 4.2 June 2005 Editors: Nick Crofts, Martin Doerr, Tony Gill, Stephen Stead, Matthew Stiff.

Copyright © 2003 ICOM/CIDOC CRM Special

Release Date : June 2005
Current main editors: Nick Crofts, Martin Doerr, Tony Gill, Stephen Stead, Matthew Stiff
Status: Closed

Available Documents:
 (.pdf) (.doc) Data example (.zip format)

Available Documents:
 (.pdf) (.doc)

Data example:
 Data example (.zip format)

Discussion:

- A collection of figures and a collection of data examples should appear together under separate pages on the site. For the moment, they appear in the relevant version.
- Reconsider the tabular representation of resources in the long run (when the site is relaunched) -maybe an HTML list.
- A number of figures representing modelling constructs are available through the path [The Model\Use&Learn\Functional Overview](#) of the model. They are outdated and need editing. To be brought up to date either with the latest official version that will be submitted to ISO or the latest version of the CRM. No agreement as to what the version will be (a stable vs the newest one), so the decision was to start a [new issue](#), where to discuss (1) the new figures and (2) what version of the CRM they should correspond to. Assign GB to do the HW.

[NEW ISSUE]: Update the modelling constructs found under [The Model\Use&Learn\Functional Overview](#).

A number of figures representing modelling constructs are available through the path [The Model\Use&Learn\Functional Overview](#) of the model. They are outdated and need editing. To be brought up to date either with the latest official version that will be submitted to ISO or the latest version of the CRM. No agreement as to what the version will be (a stable vs the newest one), so the decision was to start a new issue, where to discuss (1) the new figures and (2) what version of the CRM they should correspond to.

How to proceed:

HW to GB to lead the discussion re the version that the new figures in Functional Overview should correspond to, and to start updating them once that has been resolved.

Issue 494: Scope-note guidelines

The document as it now stands forms the result of joint work by EC, MD, TV, PR and the last editing round has further involved EC, MD, WS, and CEO.

EC mentioned that the current form of the document can be considered as done (except for a small set of clarifications that are still open in the [table of comments](#)) and proposed that they be discussed in a [new issue](#) (at least among MD, CEO, WS, TV and RS).

The version that EC last edited can be uploaded on the CIDOC repo and replace the existing one on the site.

[NEW ISSUE]: Pending revisions on the Scope-note writing guidelines

The current form of the document is subject to a set of clarifications that are still open (see [table of comments](#)). These comments will be discussed independently in the current issue (topics it involves are: substance/identity/unity criteria for defining classes, examples of scope notes that follow the guideline <or improving the existing scope-notes>).

HW for MD, CEO, WS, TV and RS

Issue 568: Incorporate changes in the model implemented by the ISO group to the versioning pipeline of the SIG

EC & PM brought the SIG up to speed with the ISO submission update. Link to presentation [here](#).

Issue 603: Contextualize issues in a more informative way

EC went over some statistics concerning participation at SIG meetings (unique participants over time, participants per meeting, meetings per individual) in order to assess how to best enable participation at SIG meetings (link to presentation [here](#)). **Overall take-home message:** new ways to participate (online meetings) have resulted in a surge in participation.

Discussion:

- The statistics presented reflect the attendance of SIG meetings rather than the active participation at meetings. Not every attendee is actively engaged, and listening in at meetings is not necessarily a bad thing –assuming one does not want to offer an opinion re. the issues discussed.
- Impossible to have operating knowledge of all issues on every topic that the SIG is working on. In that sense it's expected that most people will attend discussions that do not closely relate to their domain of interest/expertise and become more active when they actually do have something to contribute to the overall discussion.
- Online and hybrid meetings have resulted in a surge in attendance, not participation necessarily.
- Training sessions for newcomers is a very good idea. The early morning workshop served the purpose of encouraging participation. Should try to hold such sessions in all future meetings.
- Mentoring professionals (who would benefit from using the CRM but feel over-encumbered from having to learn the model first) use the CRM seems worth the effort. We should be able to identify and engage said individuals/institutions through CIDOC. The idea would be to match each SIG member to another CIDOC member that is interested in learning about using the CRM and do the mentoring on a one-to-one basis (online) and report back at the meetings. International Institute for Conservation has adopted this practice and it seems to be working fine.
- Proposal to distribute questionnaires of the type “Was the meeting up to your expectations?”/ “What can be improved?”, etc.

How to proceed:

HW: TV will put together a proposal for one-on-one mentoring, that can be shared with the board of CIDOC. To be shared with SdS, MD, & CEO by the end of the Christmas holidays.

Reschedule the 57th CIDOC CRM SIG, 50th FRBR/LRMoo SIG & ISO/TC46/SC4/WG9 Meeting

The meeting was originally scheduled to be held on the last week of September (26-29 September 2023) at FORTH. There are two competing events scheduled for the same week however: Researchers' night (which means that all the conference rooms have been reserved for the whole week) and the CIDOC Conference (which means that most SIG participants won't be able to make it). The alternative would be to have it on the 10-13 October 2023 at FORTH.

No objection.

Issue 563: Adoption and governance

Link to presentation by PM [here](#).

Open-ended questions addressed to the SIG.

Discussion points:

- **Overall duration of a translation project:** it depends on the time and effort a given translation group can put into the task
- **Assessing the quality of the translation:** samples needed, also review of documents that have been generated to guide the translation process (style-guides, keeping track of decisions on how to translate a particular term <class, property>, etc.). Translating teams need to report to the SIG any ambiguities and overall issues that need to be resolved for the translation to be completed.
- **Time that it takes the SIG to assess the quality of a translation:** depends on who among the SIG members is able to assess the quality.
- **Legal agreement:** The SIG cannot sign a binding contract. It's more like an MOU, that does not entail legal commitments. It could be an agreement formed in the CRM-SIG that could be shared with CIDOC board. Licensing should follow the CC-BY 4.0 (that characterizes the CIDOC CRM Specification Document).
- **Training can also target translation groups**
- The Translation Guidelines WG should be in direct contact with the SIG, mention ambiguities as soon as they are perceived, contact the editors and create issues on the list.

How to proceed: Seeing as CHIN seems to be the organization requiring that there be a partnership policy, assign HW to PM to provide a template for a non-binding document that describes the goal towards which the Translation Guidelines WG and the SIG are working towards achieving to be assessed by the SIG.

Translation methods observed by different initiatives –open discussion among representatives of official translation teams.

Open ended discussion lead by PM & MvR. Link to PM's presentation [here](#). Link to AG's presentation [here](#).

Discussion points:

- Patterns that have been identified as suboptimal (or inconsistent) expressions (*the (more) (fully) developed|articulated path*), can they be traced across the text? Do translation memories used pick out such expressions?
 - The European French Translation Initiative branch are currently building vocabularies of errors that they come across in the text during the translation. Since validation happens within each logical group that gets translated, such linguistic errors are consistently edited. It is possible that a separate validation step for inconsistencies across groups will need to be implemented, in which case, it would be done later on in the pipeline.
- Such resources should be made available at the SIG level and for everyone involved in a translation initiative.

- The translation initiative forms a training group as well, because it brings together people from different backgrounds, with different levels of familiarity with the CRM, so explaining how the model works is a major part of the translation effort.
- Canadian and European translation initiatives have developed tools and methods in parallel, it would be interesting to converge these things into one consistent guideline/pipeline at some point.

Wednesday 7 December 2022

Issue 364: Create Profile Markup Language/Schema/ Ontology Profiles

How to build and manage application profiles in OntoME (Presentation by Vincent Alamercery). Link to presentation [here](#).

Issue 588: Common Policy / Method for Implementing the .1 Properties of Base and Extensions in RDF

Subtopics:

How/where to provide scope-notes for .1 properties

Competing proposals:

- i. At the end (or near the end) of the main property's scope note
- ii. Below the definition of the .1 property
- iii. At a new section "CIDOC-CRM Property of Property Declarations"
- iv. Add a section "Properties" that's placed right below the scope-note of the property and right above the examples section.
- v. Combine options (ii) and (iii), i.e., include the .1 property scope-note in the property definition, but also link to a separate section "CIDOC-CRM Property of Property Declarations". Difficult to copy the text in multiple places

Discussion points:

For proposal (i): it would call for a different style guide for the scope-note of the .1 property, otherwise it would not be picked up automatically in the .1 properties RDF file.

For proposals (i) & (iv): Especially if there is more than one kind of .x property (like in CRMarchaeo), there should be an equivalent number of styles corresponding to the scope-notes of each type of .x property.

For proposal (iii): it is easier to automatically generate the RDF file for .1 properties.

For proposal (ii): the description of the .1 property is dependent upon and should in that sense appear close to that of the main property. Especially since the examples represent the .1 property as a continuation of the main property.

Overall comments:

- .1 properties should be redrafted making use of the scope-note writing guideline. They are systematically the most ill-drafted.

- At some point, we should revisit style guides and formulize the scope-notes even more, to ensure that the transitivity/reflexivity/symmetry statements are found in the same part of the scope notes. The same thing should apply to shortcuts and .1 properties. It relates to issue 494 - scope note writing guideline.

The SIG voted on option (iv) which was considered the most widely adopted.

Outcome of the vote.

In favor: 12 (8 in person, 4 online)

Against: None

(18 participants abstained)

Decision: implement proposal (iv) above –namely: add a section “Properties” that’s placed right below the scope-note of the property and right above the examples section

Statement about the relation of the CIDOC CRM base file and the PC module (.1 properties declaration)

PF read the statement he drafted for the .1 properties to be put at the end of the comments section of the CRMbase file. No counterproposals, everyone happy with the content of the statement.

The SIG voted on introducing the statement for the RDFS implementation of CIDOC CRM at the end of the CRMbase file, as proposed by PF.

Outcome of the vote

In favor: 12 (7 in person, 5 online)

Against: None

(18 participants abstained)

Decision: implement. The statement can be found in the [appendix](#)

Including an introductory text and an instantiation example in the PC module.

The SIG went through the introductory text & instantiation example in the PC module for v7.1.1 (proposal by PF).

The SIG voted on enriching the PC module for subsequent with the introductory text and instantiation example as proposed by PF for v7.1.1.

Outcome of the vote

In favor: 12 (7 in person, 5 online)

Against: 1 (none in person, 1 online –on the grounds that the same content could be rendered through rdfs:comment instead)

(17 participants abstained)

Decision: add the XML comments in v7.1.1 and subsequent stable versions. The enriched file (e.g., for version 7.1.1) can be found [here](#). How the content is represented (xml comments vs rdfs:comment) can be dealt with in a separate issue.

Clarify the classes/properties that do not form part of the official definition of the CIDOC CRM

The SIG went through the XML comments in the PC file for v7.1.1 stating what forms part of the definition of CIDOC CRM [.1 properties] and what doesn’t [PCs (proposal by PF -found at the enriched file)].

Discussion:

- While the comments are useful and self-explanatory, there are other things in the RDFS files that do not form part of the definition of CIDOC CRM (other than the contents of the PC file). P81-P82a/b for instance.
- Need to mark all the elements that are part of the implementation of the model as such.

HW: PF to look at the different kinds of statements

Did not go through the points F through I of the working document for want of time.

Erlangen OWL and CRM RDF. Steps towards CRM OWL (Presentation by Mark Fichtner)

Link to presentation [here](#)

Discussion points:

Regarding the competing practices wrt to using class/property labels as part of the identifiers. It has not always been the case for the CRM, it was a practice that got introduced at some later point.

In principle, URIs should only contain the E & P numbers. However, before deciding on such a drastic change that will affect multiple implementations, the SIG should consult with the community using the CRM for implementations.

Issue 615: scope note of E13 Attribute Assignment

Open-ended discussion regarding questions posed by WS on the last paragraph of E13 Attribute Assignment. Said questions will no longer be relevant if the SIG accepts the proposal by MD to delete the paragraph.

- "All cases of properties in this model that are also described indirectly through a subclass of E13 Attribute Assignment are characterised as "short cuts" of a path via this subclass. This redundant modelling of two alternative views is preferred because many implementations may have good reasons to model either the action of assertion or the short cut, and the relation between both alternatives can be captured by simple rules."

Decision: postpone until a proposal has formally been made

Other questions raised by WS to the SIG:

- P38 "deassigned" is only for Identifiers. How would one express the general situation when an attribute gets deassigned?
(Both P37 "assigned" and P38 "deassigned" are in fact subproperties of P141 "assigned". On the other hand, according to its scope note P1 is a shortcut for "P140i was attributed by E15 Identifier Assignment P37 assigned" but the counterpart "P140i was attributed by E15 Identifier Assignment P38 deassigned" is not mentioned.)
- Both E15 and E17 can be applied to any E1 CMR Entity. Why is there a subproperty P41 "classified (was classified by)" of P140 "assigned attribute to (was attributed by)" for E17 Type Assignment, but no subproperty of P140 for E15 Identifier Assignment? It's a matter of consistency.

Discussion:

- **“Deassigning an attribute”** (i.e., a property extending to the superclass of E15 Identifier Assignment) would mark one of two possible situations:
 - a change of opinion re. some property/feature of a thing,
 - making a statement that a particular proposition is not the case.
- **Deassigning identifiers** on the other hand stands for a common practice in museum documentation that refers to the procedure of removing an identifier from an object. In that sense, it does not document a change of opinion; rather, it states that the particular identifier has become obsolete/is no longer in use.
- The scope note of P38 should reflect the above reasoning, so start a [new issue](#) to redraft it accordingly.
- Reclassification of species is something that has been documented at various instances in marine biology, has interesting implications for E17 Type Assignment. To be discussed into a [new issue](#). Assigned to GB to formulate it properly.
- Re the lack of subproperty of P140 for domain E15 Identifier Assignment. No one seems to remember what motivated this “lack of symmetry”. Discussion to continue in the thread for issue 615.
- Regarding the proposal to delete the last paragraph from the scope note of E13 Attribute Assignment: The proposal needs to be formally made and discussed before it can be decided upon. A working document to support the reasoning backing this proposal and implications of implementing it would be helpful

[NEW ISSUE]: Redraft the scope note of P38 deassigned

An issue where to discuss updating the scope note for P38 according to the decision in [Issue 615](#).

HW: MD, WS, SdS

[NEW ISSUE]: reclassifying species – implications for E17 Type Assignment

Reclassification of species is something that has been documented at various instances in marine biology, has interesting implications for E17 Type Assignment. To be discussed in a new issue.

HW: GB assigned with formulating it properly.

Issue 476: Pxxx represents entity of type

TV proposed to not deprecate P199 represents instance of type from the CRM, on the grounds of it having been implemented already in many systems. TV also made a case against introducing typed properties in the model from now on.

Furthermore, it was proposed that the Guidelines to writing scope notes document (see issue 494) should contain a statement about the existence of typed properties. The idea is to let people know that they shouldn't be proposing typed properties from now on.

The SIG voted on keeping P199 represents instance of type in the v7.2.x branch of CIDOC CRM.

Outcome of the vote

In favor: 12 (8 in person, 4 online)

Against: None

(18 participants abstained)

The SIG voted on adding a statement about the typed properties in the guidelines to writing scope notes.

Outcome of the vote

In favor: 11 (8 in person, 3 online)

Against: None

(19 participants abstained)

Decisions:

- Keep P199 in the v7.2.x branch, quantification set to (many-to-many)
HW:
MD to provide a quantification statement for P199;
RS to revise the reformulation of the scope note and the axiom proposed by MD in the email thread for the issue ([7 December 2022](#)). If this happens long before the next meeting, then it can be put to an evote. If there are things to be discussed still, it can be brought to the SIG in the meeting in May 2023.
- Add the statement about the typed properties in the guidelines to writing scope notes.
HW: TV.

Issue is kept open, until all the subtopics have been resolved.

Issue 610: Deprecate Typed Properties in CIDOC CRM?

TV gave some background on the issue. In particular there are 3 separate subtopics to be addressed:

1. Whether to deprecate existing typed properties in CRM base.
2. Whether the CRM inverse properties can be typed properties.
3. Considerations of the temporal validity of negative types properties, i.e. for what period the closed world exists.

Re. (1):

P125 used object of type is the only other instance of a TP found in the CRM. **Proposal not to deprecate it**, because it has been used in multiple implementations.

The SIG voted on keeping P125 in CIDOC CRM.

Outcome of the vote

In favor: 15 (11 in person, 4 online)

Against: none

(15 participants abstained)

Decision: do not deprecate

Re (2):

- TV reported that in principle there shouldn't be any TPs in inverse paths, because inverse paths do not conform to the overall pattern ($s \rightarrow p \rightarrow o$) ($o \rightarrow p2 \rightarrow t$).
 - MD has done some relevant work (meta-CRM) in the past and thinks that there may be some still in the inverse properties. He is going to take up HW on that, together with TV. To be dealt with in a [new issue](#).
- P32 used general technique *IsA* P125, which itself stands as a shortcut for E7. P16: E70. P2: E55. There is no registered instance of a technique over which this is shortcutting. Is the subproperty still valid if there is no instance of technique?
 - Make this a part about the inheritance of strong vs weak shortcuts. To be discussed in a [new issue](#). For MD, WS, CEO and TV to fully flesh out.

Re (3):

MD presented 3 competing views on the temporal validity of NTPs –namely their temporal validity interpreted as (i) eternal, (ii) continuous from a point on in time, (iii) continuous in relation to a period of observation –and made the argument in favor of (iii) being the safest option in terms of reasoning.

Discussion:

For interpretation (i): there are cases that one can safely claim for something not being present that it never has been or never will be present (i.e., in a medieval manuscript that had never had leafmarks on it, it would be weird to claim that it is possible to add leafmarks to it in the current age, or at some later stage).

The analysis by MD is relevant for issue [609](#) (under which it was originally posted). No effect on implementing NTPs for RDFS.

Way to move forward: MD, SdS, TV, PF, WS to discuss the temporal validity of NTPs (and overall Ps). Inform 609 with this decision.

Summary of decisions:

- Keep P125 in CIDOC CRM
- Start a [new issue](#) about TPs in CRM inverse properties
- Start a [new issue](#) on the inheritance for strong and weak shortcuts
- Move the discussion re. the temporal validity of NTPs to issue [609](#)
- Close issue 610 on the grounds of there being nothing left to do in this thread

[NEW ISSUE]: Are there TPs among the CRM inverse properties?

Reconsider work from meta-CRM in this context.

HW assigned to MD, TV

[NEW ISSUE]: Inheritance of strong and weak shortcuts

P32 used general technique *IsA* P125, which itself stands as a shortcut for E7. P16: E70. P2: E55. There is no registered instance of a technique over which this is shortcutting. Is the subproperty still valid if there is no instance of technique?

Make this a part about the inheritance of strong vs weak shortcuts. To be discussed in a new issue.

HW: For MD, WS, CEO and TV to fully flesh out.

Issue 622: Redraft & update intro to CRMarchaeo

GH & CEO informed the SIG that the introduction to CRMarchaeo has been extensively redrafted; they have incorporated all the decisions of the relevant set of issues in it. What still needs to be done is edit some graphics (see A7 Embedding). Once that has happened, the new version of the CRMarchaeo intro will be put to an evote.

HW: CEO to take care of the evote.

Issue 621: Update synchronization btw CRMarchaeo and CRMbase

CEO walked the SIG through his HW –properties of A1 Excavation Processing Unit (IsA S1 Matter Removal, and IsA S4 Observation) that are problematic (in the sense that they assume contradictory semantics for class A1):

- AP4 produced surface (was surface produced by): A10 Excavation Interface
- AP5 removed part or all of (was partially or totally removed by): A8 Stratigraphic Unit
- AP10 destroyed (was destroyed by): S22 Segment of Matter

AP4 produced surface (was surface produced by)

AP4 is declared a subproperty of both P92 brought into existence and P108 produced. However, P108 IsA P92, which means that one of the two superproperty declarations is superfluous. Deciding which one to keep depends on the choice of superclass relation for A1 (the domain of AP4).

Proposal: drop the AP4 produced surface IsA P92 brought into existence, which means that we also have to drop that A1 Excavation Processing Unit IsA E63 Beginning of Existence in favour of A1 Excavation Processing Unit IsA E12 Production.

Discussion points:

- the production of the surface in the course of an instance of A1 is necessary
- the added value of declaring AP4 IsA P108 (and A1 IsA E12) is not clear, in the sense that the surface produced is a by-product of the instance of A1.
- A1 can be made a subclass of almost all classes. It's core to CRMarchaeo, a fact which can be captured through multiple instantiation rather than excessive subclassification.

The SIG voted the proposal.

Outcome of the vote

In favor: 7 (6 in person, 1 online)

Against: 3

(20 participants abstained)

Decision: no consensus.

How to proceed: HW to the CRMarchaeo editors to revisit and come up with a new proposal (or same proposal supported by new evidence). Evidence for/against the proposal:

- How does A1 benefit from using properties that are particular to E12 that are not available for E63?
- How does making A1 IsA E63 (hence not E12) prevent unintended modelling?

AP5 removed part or all of (was partially or totally removed by)

Ap5 is currently declared IsA P31 has modified (with domain E11 Modification). However, the domain of AP5 is A1 (that IsA S1 Matter Removal (IsA E7 Activity) and IsA S4 Observation (IsA E13 Attribute Assignment IsA E7))

Proposal: drop the AP5 IsA P31 has modified and make it IsA O1 diminished [D:S1 Matter Removal, R:S10 Material Substantial]

The SIG voted the proposal.

Outcome of the vote

In favor: 8 (6 in person, 2 online)

Against: 0

(22 participants abstained)

Decision: make AP5 IsA O1 diminished

AP10 destroyed (was destroyed by)

AP10 is currently declared IsA P93 took out of existence (with domain E64 End of Existence). This means that A1 needs to be declared IsA E64 as well. Alternatively, the superproperty relation needs to be dropped.

Proposal: Keep the superproperty relation (AP10 IsA P93 took out of existence [D:E64 End of Existence, R: E77 Persistent Item])

The SIG voted the proposal.

Outcome of the vote

In favor: 8 (6 in person, 2 online)

Against: 0

(22 participants abstained)

Decision: keep the AP10 IsA P93

Issue 584: AP32 discarded into (scope note refinement)

CEO presented the HW –redrafting the scope note of AP32 to include a clause about setting its quantification to many-to-many, because it was not self-evident as it stood previously.

The SIG voted on adjusting the scope note as proposed by CEO.

Outcome of the vote.

In favor: 12 (8 in person, 4 online)

Against: None

(18 participants abstained)

The updated scope note can be found in the [appendix](#)

Issue closed

Issue 549: revise TX5 Reading vs TX6 Transcription

PF walked the SIG through changes to the CRMtex model implemented since the 54th SIG meeting. Link to HW presentation of how the overall model is altered and examples instantiating the added classes and properties [here](#).

Discussion points:

- The modeling constructs demonstrated (different kinds of recognition -autoptic, autoptic and assisted, digital, using replicas) could be abstracted upon, with the aim of being used in other disciplines as well. Discerning/reading architectural patterns shows a lot of similarity.
 - One could use moulds or could examine the building or view pictures of it etc. Maybe a more generic rendition of these modeling constructs could become material for CRMsci.
 - There is a potential interface with CRMdig, when we start talking about digital representations and processing.

Proposal: accept all changes listed by PF in order to produce a new stable version (v2.0 –the new model comes with substantial revisions, addition of new classes/properties etc.)

It was difficult to discern what part of the editing undertaken falls in the scope of implementing previous decisions and which part formed a proposal of the editorial team.

It was suggested that PF represent the two kinds of changes (previous decisions incorporated in the model vs. new suggestions for editing) differently and bring the latter to the SIG to decide, in the context of the 55th SIG meeting.

Issue 556: Content of the minimal vocabularies for restricting the CIDOC CRM Types

TV brought the SIG up to speed with the developments in the issue. At present things stand like that:

- MD has provided the functional role of the minimal vocabulary (text in the [appendix](#)) & **HW**: SdS to proof-read it.
The text is to be added to the introductory section of the CIDOC CRM, right after “About types” after SdS is done editing it.
- The deprecated classes that are to be rendered through types that were agreed upon can also be found in the [appendix](#).
 - **Discussion points:**
 - E40 Legal Body deprecated in favor of E74 Group: a concept from AAT –namely [corporations](#) –has been identified as the closest match to what E40 expressed.
 - TV thinks this is particular to businesses, whereas MD believes that the phrase “commonly formed as business enterprises” does not exclude other non-business-oriented groups/institutions.
 - An alternative from AAT would be “[corporate bodies](#)”, but nobody seemed thrilled about it either.
 - The SIG voted on replacing E40 Legal Body with the AAT definition for “corporations”
Outcome of the vote.
In favor: **none**
 - **Decision**: The alternative option for the SIG is to reconsider “corporate bodies” or produce a scope-note that matches the intended semantics of the E40.
 - E45 Address deprecated in favor of path E41 Appellation.P2 has type: “Address”, and use the concept “[street addresses](#)” from the AAT.
 - The SIG voted on replacing E45 Address with the AAT definition for “street addresses”
Outcome of the vote.
In favor: 12 (8 in room, 4 on line)
Against: none
(18 participants abstained)
 - **Decision**: use the identified AAT concept.
 - The HW as a whole can be accessed [here](#).

Issue 608: New examples for P161 *has spatial projection*

E92 Spacetime Volume, E93 Presence and related properties; examples from Notre-Dame collapsed arch (Presentation by Anais Guillem)

Link to presentation [here](#), modelling constructs represented [here](#)

How to proceed

HW: MD, AG, CEO to work more on the example. Could aim towards a publication with this example. Could then reference to it in the examples for E92, E93, P161.

Issue 492: Spatiotemporal formalization about the presence of parts.

WS walked the SIG through his [HW](#) that explores the spatiotemporal relations of E79 Part Addition/E80 Part Removal (plus the relevant set of properties) with parthood through E93 Presence.

E79/E80 stand as the long forms for shortcuts used to state that one thing is composed of another thing, an instance of either E79/E80 should imply the existence of a parthood relation (P46 between the added/removed part and the whole it augmented/was removed from).

This inference is warranted by the scope note of P46, which explicitly states that a thing that forms part of another thing does not have to be present for the entirety of the containing thing's existence (it could have been added later on or removed at some point).

The existing axiom for parthood

$$(P46(x,y) \Rightarrow (\exists uzw)[E93(u) \wedge P195i(x,u) \wedge E52(z) \wedge P164(u,z) \wedge E93(w) \wedge P195i(w,y) \wedge P164(w,z) \wedge P10(w,u)])$$

defines the relation of parthood through the relevant timespan for which it holds that the E93 Presence (w) of E18 Physical Thing (y) falls within the E93 Presence (u) of E18 Physical Thing (x).

WS suggested that the axiom for P46(x,y) can probably be re-expressed in a more concise manner (but that can be done at a later stage) but the relation between the time that the E79 Part Addition took place and the time that the contained thing's E93 Presence falls within the E93 Presence of the containing thing still remains implicit.

His suggestion was to render this relation through P182, or a more suitable property

E79 Part Addition. P182 ends before or with the start of: the time span of the E93 Presence (of the contained thing in the containing thing)

The axioms proposed are in functional notation, WS will provide one that's consistent with the one used in the specification document. He asked the SIG for feedback regarding whether the axiom should be added in E79 (which is conceptually right, but goes against practices for class declarations) or P46.

Discussion points:

The SIG needs to reflect some more on the identity conditions of instances of E18 that were added/removed for both E79 and E80.

- For something to count as an instance of E79 Part Addition, the added part needs to have existed prior to becoming part of another thing.
- Also, it is often the case that a thing comes into being when 2+ other things come together. This would be a production event, for which we can claim parthood, but would not qualify as an E79 Part Addition. The shortcut for E79 should not hold in this case.
- Instances of E80 Part Removal can involve removing a part that either has or hasn't had an independent ontological existence before its removal from the containing thing. Removing a part of an object might create a new object as well. There are more scenarios to be considered before allowing the parthood to stand invariably as shortcut for all instances of part removals/destructions.
- Once the SIG has concluded on their form, the axioms should appear under P46 not the classes mentioned in the long path.

How to proceed: WS will continue working on that, taking into consideration the SIGs feedback.

Issue 617: Is $P7(x,y) \wedge P89(y,z) \Rightarrow P7(x,z)$ still regarded as true?

WS gave a summary of the issue, which seems to lump together arguments on notational preferences, ontological considerations and inferencing mechanisms in some hypothesized knowledge base.

Discussion points:

- The utility of the points raised by WS is indisputable from the perspective of implementation.
- FOL is formalizing the ontology, not the knowledge base; ontological considerations should be discussed independently from knowledge base implementation issues.
- According to CEO's understanding, replacing the old axiom for P7 (according to which stating that an event occurred over some place x, could give rise to valid inferences stating that it occurred at any place y including place x) with the current axiom (stating that P7 shortcuts over P161 and P89 and makes the links to reference spaces by P157), it has no consequences from the perspective of the knowledge base.
- The issue has drifted substantially from the question of introducing the axiom $P7(x,y) \wedge P89(y,z) \Rightarrow P7(x,z)$ in the CRM and the issue should close (and assuming that WS wants the axiom introduced, he should start another issue).
- The rest of the discussion (Ontological vs Knowledge Base considerations) can carry on in a more focused issue. WS, CEO, MD can help shape it.
- Proposal to introduce a clause in the section Reality, Knowledge Bases and CIDOC CRM where it is explicitly stated that the FOL and the quantifications are not intended as rules for implementing the ontology, but they serve to disambiguate the ontology's relation to reality (if it's not there).

Issue closed

Issue 616: shortcuts in P50 has current keeper, P52 has current owner, P55 has current location CEO gave a summary of the issue: the FOL notation for P50/P52/P55 (cast as a weak shortcut) is inconsistent with what is stated in the scope-notes (cast in terms of "if and only if"). Furthermore, the weak shortcut notation implies the existence of something unknown, which from an implementation point of view is not good, but from an ontological point of view should make no difference.

Another point raised is that "current" properties need external curation and also break the basic assumption that a CIDOC CRM KB/database store accumulate history. CEO proposed to deprecate them. They were originally introduced because they were used in museums back in the 90s. Time to re-examine this.

Discussion points:

- "Current" relates to the definition of Situation in a sense, and specifically to what the maintainers of the knowledge base relate what is in the knowledge base to what they know. It is a question for CRMInf really.

How to proceed:

- Before resolving to deprecate the properties, there should be an alternative, i.e., a way to maintain and exchange knowledge about the current validity of what has been documented.
- Start a [new issue](#) to discuss the requirements for expressing current knowledge, and once there is agreement on that, consider the repercussions of deprecating P50/P52/P55 in the CRM.
 - To take into consideration when outlining the new issue:
properties are means to express some knowledge, for ownership, the qualifications current vs former, represent knowledge on the ownership (and changes thereof) for some object in time. The problem stems from the effort of trying to express a complex property (the ownership) in simplistic terms.

Issue closed

[NEW ISSUE]: What is required for expressing current knowledge?

Upon discussing issue 616, the SIG resolved to start a new issue where to investigate what is required for expressing current knowledge. After this has been agreed upon, the SIG may discuss deprecating P50/P52/P55 and the repercussions of doing so.

Issue 613: Inverse shortcuts

CEO maintains that:

- Weak inverse shortcuts are to be represented as axioms of the form $\text{lefthandside}(x,y) \Rightarrow (\exists z)[\text{righthandside}(x,y,z)]$, which he believes should be avoided. However, previous discussions for issues 617, 616 have revealed that from an ontological point of view they do not pose a problem, so he's OK with keeping them.
- A new term should be introduced instead of the opaque "Weak Inverse Shortcut" (though it's not the most pressing thing to do)
- Make a list of all weak inverse shortcuts in CRMbase and family models. In his HW he has provided such a list for CRMbase and CRMarchaeo (details in the [appendix](#)). Maintainers of other family models should do the same.

Discussion points:

The weak/strong shortcut definitions appeared in the introductory section of the CIDOC CRM. At some point, a decision was made to not distinguish among the two types and the relevant text was subsequently deleted, on the grounds of never having encountered them in practice. Since then, all shortcuts are merely referred to as plain "shortcuts".

The introduction explicitly states that there are no inverse shortcuts. But we have had shortcut properties such as P26, P27 since the beginning. It is probably a mistake -part of an overzealous editing.

Proposal:

- Relabel the types of shortcut in a more intuitive way, namely:
 - **Shortcut:** indicates that the long path implies the short path.
 - **Inverse shortcut:** indicates that the short path implies the long path
 - **Strong shortcut:** indicates an equivalence relation between the long and the short path

- Introduce the terms above in the specification document of CIDOC CRM (under Terminology).
- Check CEO's list. Mark the properties in the text as shortcut, inverse shortcut, strong shortcut.

The SIG voted on the proposal (introduce terms for “shortcut”, “inverse shortcut”, and “strong shortcut” in the terminology; characterize shortcut properties as such in the declarations).

Outcome of the vote.

In favor: 12 (8 in person, 3 online)

Against: None

(18 participants abstained)

Thursday 8 December 2022

Issue 620: Temporal proximity of events for O13 triggers

Proposal for a scope note (and FOL) reformulation of O13 triggers, in order to match the semantics of temporal precedence of the triggering event and ensuing influence to the triggered event (see figure 6 of the introduction section). The details of the proposal can be found in the [appendix](#).

Discussion points:

- O13 triggers vs O13 triggered. Why not in the past tense as stated in the intro to CIDOC CRM?
- The requirement for the triggering event to have finished before the beginning of the triggered event is not all too clear.

The $O13(x,y) \Rightarrow P182(x,y)$ inference is contested.

Especially in view of the type of event that can function as a trigger for some other mentioned in the scope note, which involve events evolving over a stretch of time:

- An earthquake can be the cause for the surface giving in or for buildings collapsing, even if the triggered events (landslides, buildings collapsing, etc.) occur prior to its completion.
- Wildfires that are triggered by a massive heatwave and draught, need not start after the triggering events (i.e., draught, massive heatwave) are concluded. If anything, they will probably only start as long as the triggering events are ongoing. It would be weird to not be able to list the heat and/or draught as a triggering event for a wildfire (like the ones in southern Europe in summer 2022).
- The types of examples mentioned in the scope note try to capture that the triggered event somehow results from a previous event, and the only way to express that is by assuming temporal precedence. Otherwise, triggered events could have predated their triggers (which is far from ideal).
- Since it is possible for multiple landslides to occur during the same phenomenon (excessive rainfall), the triggering event (excessive rainfall) can be subdivided into the bits that are relevant for each triggered event ($landslide_{1, \dots, n}$). This should be reflected in the scope note.
- Splitting an event into multiple triggers is also suboptimal. It looks like the relevant part of the event gets its identity as a triggering event, based on the event that it caused. Needs reconsideration, because it postulates splitting up events into as many pieces as there are implications to them.

Proposal to add the clause “The association of the two events is based on their temporal proximity, with the triggering event ending before or when the triggered event starts” in the scope-note of O13. If there are objections to the overall semantics of the property, they can be discussed in a designated new issue:

The SIG voted on the proposal above.

Outcome of the vote.

In favor: 6 (3 in person, 3 online)

Against: None

(18 participants abstained)

Decision: Add clause to the scope-note.

Issue closed

Issue 612: Diagrams for Position Measurement and properties in the introduction of CRMsci
The SIG reviewed HW by AK & TV (diagrams and accompanying text for S23 Position Measurement and properties (Figure 9), plus an example instantiating them (Figure 10), to be displayed in the introduction of CRMInf). The details can be found in the [appendix](#).

Proposal: Vote (separately for each diagram & short description pair) to be admitted in the introduction section of CRMsci.

- The SIG voted on admitting Figure 9 & accompanying short description in the introduction section of CRMInf.

Outcome of the vote.

In favor: 8 (6 in person, 2 online)

Against: None

(16 participants abstained)

- The SIG voted on admitting Figure 10 & accompanying short description in the introduction section of CRMInf.

Outcome of the vote.

In favor: 9 (6 in person, 3 online)

Against: None

(15 participants abstained)

Decision: Introduce both Figure 9 & Figure 10 in the introduction section of CRMInf.

Issue closed

Issue 611: Scope notes for the properties of Position Measurement

The SIG reviewed the scope-notes proposed for new properties of S23 Position Measurement (HW by TV, MD, GH), an outline of which was given in the 54th SIG meeting.

The properties in question are:

- O30 determined position (was determined by)
- O31 has validity time-span (is time-span validity for)
- O32 measured position (was located by)

Furthermore, the SIG reviewed the examples proposed for S23 Position Measurement.

The details of the property definitions for O30 through O32, as well as the examples of S23 can be found in the [appendix](#).

Discussion points: The WD mentions the following two properties without any further reference to them, which creates the (false) impression that they are properties of S23:

- S23 Position Measurement. *Oxx4 observed situation (situation observed by):* Sxx Observable Situation
- E93 Presence. *Oxx5 forms part of (consists of):* Sxx Observable Situation

However, the former is only presented as part of an example in which the S4 Observation connected to an Observable situation by this property, is simply instantiated by a more specific class (S23).

In any case, seeing as there is no HW for the properties of Sxx Observable Situation in this document (nor will they make it to CRMsci v2.0), it is proposed that discussions relative to Oxx4, Oxx5 above be moved to a new issue.

HW: AK to formulate said issue.

Proposal to admit the definitions for properties O30, O31, O32 and the examples for S23.

The SIG voted to admit the definitions for properties O30, O31, O32 and the examples for S23.

Outcome of the vote.

In favor: 11 (8 in person, 3 online)

Against: None

(13 participants abstained)

Decision: introduce the definitions & examples in CRMsci v2.0.

Issue closed

Issue 623: Editorial check of CRMsci examples

TV walked the SIG through the editorial changes that need be implemented in CRMsci before the release of v2.0. The following subtopics have been identified:

Clause about the location of an S2 Sampling Activity (Introduction section, short description for Figure 3).

Proposal to add the clause in [blue](#) to the short text description above Figure 3, to distinguish S2 Sample Taking from S19 Encounter Event. For details see [appendix](#).

The SIG voted to add the clause in [blue](#) above.

Outcome of the vote.

In favor: 12 (9 in person, 3 online)

Against: None

(12 participants abstained)

Decision: introduce clause in [blue](#) in CRMsci v2.0.

Diagram of S19 Encounter Event (also contains instances)

Proposal to add the clause in [blue](#) to describe Figure 8—the diagram for S19 Encounter Event in the Introductory section (about S4 Observation). Details in the [appendix](#).

The SIG voted to add the clause in [blue](#) and the diagram concerning S19 Encounter Event.

Outcome of the vote.

In favor: 11 (8 in person, 3 online)

Against: None

(13 participants abstained)

Decision: introduce clause in [blue](#) & Figure 8 in CRMsci v2.0.

S2 Sampling (examples tidying up)

The following example is missing a reference. Nobody knows anything about how it got admitted in the model.

- the collection of specimen ‘FHO – Benth. - 1055’ from a plant of the species ‘spiciformis’ in Zambia by Bullock, A.A. in 1939 (S2)

By CRMsci Editors’ decision: keep it despite lacking a reference.

Wrong inheritance from E16 Measurement in the scope-note of S3 Measurement by Sampling

S3 Measurement by Sampling **IsA** S2 Sampling **and** **IsA** S21 Measurement. Given that E16 Measurement **IsA** E21 Measurement (according to decisions for Issue [537](#)). Proposal to edit the scope accordingly (see [appendix](#) clauses in [blue](#)).

The SIG voted to change the scope-note as proposed.

Outcome of the vote.

In favor: 11 (8 in person, 3 online)

Against: None

(13 participants abstained)

Properties of S4 Observation update

On the grounds of having decided not to include Sxx Observable Situation in v2.0 (see issue [611](#)), the property linking to it from S4 Observation cannot be introduced in v2.0 either.

A proposal has been made to ultimately substitute S4 Observation. O9 observed property type: S9 Property Type **and** S4 Observation. O16 observed value: E1 CRM Entity, with S4 Observation. Oxx *observed:* Sxx Observable Situation.

CRMsci Editors’ decision: The specifics of the proposal have not been worked out yet, so O9 and O16 are to be kept in CRMsci v2.0.

References to papers in scope-note formulations

In general, citing papers for scope-note formulation goes against the SIG’s practices. However, there should be a way to document that S11 Amount of Matter heavily draws on:

- Gangemi, A., Guarino, N., Claudio, M., Oltramari, A. & Schneider, Luc. (2002). Sweetening ontologies with DOLCE. Proceedings of the 13th European Conference on Knowledge Engineering and Knowledge Management. 2473. 166-181

Proposal: Add a clause stating that “This follows the principles outlined in Gangemi et al. ...”. Then reference the paper.

How to proceed: TV (HW) to add this clause and put the reformulated scope-note up for an evote.

Missing reference in S14 Fluid Body

Fluid bodies need to be defined in terms of geological formulations, nobody in the SIG has been able to provide such a definition thus far.

By CRMsci editors’ decision: Leave the scope-note as it is for CRMsci v2.0, and if there is active interest in changing it, start a new issue on S14.

Missing reference in an example for S15 Observable Entity

- the flight of a crow observed over the waters of Minamkeak Lake during the summer of 2015 (E5)

HW: It’s most likely that MD came up with this example, he should provide the reference for it. If he hasn’t made note of it, then just leave it unreferenced.

Missing reference in an example for S20 Rigid Physical Feature

- the surface Surf13 (created by the excavation process on 3/3/2003) the surface Surf313 (created by the excavation process on 3/3/2003) the surface Surf313 (created by the excavation process on 3/3/2003)

By CRMsci editor’s decision the example will be deleted, as it is most likely a fictitious one. To be substituted by a suitable example from CRMarchaeo, one that

HW assigned to CEO to provide an example from CRMarchaeo for uncovered surfaces

S22 Segment of Matter missing an example

HW assigned to SdS, MD, and CEO to check in CRMarchaeo for a suitable example

O3 sampled from (was sample by) – example approval

- Water Sample Taking 74001(S2) *sampled from* the acquifer (S10) that overlaps with borehole 10/G5 (Lucchese et al., 2013 and Kritikos et al., 2013)

The SIG voted to admit the proposed example.

Outcome of the vote.

In favor: 8 (6 in person, 2 online)

Against: None

(16 participants abstained)

O4 sampled at (was sampling location of) -example approval

- Water Sample Taking 74001(S2) *sampled at* borehole 10/G5 at depth 0 which falls within the water district 10/G5 in Central Macedonia (E53) (Lucchese et al., 2013 and Kritikos et al., 2013)

The SIG voted to apprv the proposed example.

Outcome of the vote.

In favor: 7 (5 in person, 2 online)

Against: None

(17 participants abstained)

O5 removed (was removed by) -approve scope note and example (add references)

Scope note:

This property associates an instance of S2 Sample Taking with the instance of S13 Sample that was taken during the activity

Examples:

- Lithology Sample Taking 201 (S2) *removed* sample 2B (S13) (Lucchese et al., 203 and Kritikos et al., 2013)

Discussion points:

- The two referenced papers form project deliverables. The database that recorded the samples is no longer maintained, following the conclusion of the project, so looking for Lithology Sample Taking 201 and Sample 2B would not return anything. The paper has been cited instead, which is suboptimal.
- Reintroduce the original reference to the database, despite it not being maintained. Make sure to add [accessed on: "date"] in the bibliography. Keep the references to the two papers as well.

The SIG voted to approve the scope-note and example.

Outcome of the vote.

In favor: 8 (5 in person, 3 online)

Against: None

(16 participants abstained)

O6 is former or current part of – example review

- J.K.'s blood sample 0019FCF5 (S12) *is former or current part of* J.K.'s blood (S14) (fictitious)

The SIG voted to approve the proposed (fictitious) example.

Outcome of the vote.

In favor: 7 (5 in person, 2 online)

Against: None

(17 participants abstained)

O7 confines (is confined by) – label mismatch with examples

The examples were previously in the past tense ("confined").

The CRMsci editors have decided to change the label on the examples to the present tense, in accordance with what seems to be the practice elsewhere (a property whose domain and range are both endurants is not likely to have an eventive interpretation).

The CIDOC CRM definition document states that:

Properties with the character of states are named in the present tense, such as "has type", whereas properties related to events are named in the past tense, such as "carried out". (v7.2.2, p.21)

O8 observed (was observed by) – reformulation of the example to use the forward going property

Proposal to change the example from the inverse to the forward form of the property, & minor reformulations

- **(OLD)**
The rotational landslide that *was observed* by engineers on the slope of Panagopoula coastal site, near Patras, on the 25th April 1971 and the 3rd May 1971 (Tavoularis et al., 2017).
- **(NEW)**
The engineers' observation on the slope of Panagopoula coastal site, near Patras, on the 25th-26th April 1971 and the 3rd May 1971 (S4) *observed* the rotational landslide at the same site (S15) (Tavoularis et al., 2017)

The SIG voted to approve the reformulated example.

Outcome of the vote.

In favor: 6 (3 in person, 3 online)

Against: None

(18 participants abstained)

010 assigned dimension – update example

Proposal to reformulate the example to make it consistent with the semantics of the range class (E54 Dimension, which is not just a number).

- **(OLD)**
The shock wave recording (S6) carried out by EPPO in 1999 *assigned* PSA_10 with value 0.0008 (E54) (Lucchese et al., 2013 and Kritikos et al., 2013).
- **(NEW)**
The shock wave recording (S6) carried out by EPPO in 1999 *assigned dimension* PSA_10 (E54) [The dimension had value 0.0008.] (Lucchese et al., 2013 and Kritikos et al., 2013)

The SIG voted to approve the reformulated example.

Outcome of the vote.

In favor: 8 (5 in person, 3 online)

Against: None

(16 participants abstained)

011 described – approve examples

- The quantitative analysis of Munsell colour data carried out by C.T. Brown in 1999 in Yucatan, Mexico (S6) *described* the slipped sherds of Mayapan period ceramics (S15) (Puck and Brown, 2015).
- The linear extrapolation of overall figure height from the size of the fingers (S6) *described* the statue of Hercules (S15) [The statue is located in Amman] ('Temple of Hercules (Amman)', Wikipedia, 2022).

The SIG voted to approve the examples.

Outcome of the vote.

In favor: 8 (5 in person, 3 online)

Against: None

(16 participants abstained)

013 triggers (is triggered by) –determine the tense on the property label & approve the examples

The tense marking of the property is a mismatch with the eventive nature of its domain and range class. The guideline listed under "Naming Conventions" in the CIDOC CRM specification document states as much.

Discussion points: Before editing systematically, we should make sure that the present tense marking is indeed an oversight. If there is a specific reasoning dictating that it be in the present, then it should make it into a guideline for everyone to know.

Proposal: change the tense on the property label to the Present in the examples (to match the label on the property declaration) for CRMsci v2.0. Reconsider for later releases. Eventually treat the label mismatches in a systematic way.

Examples:

- The earthquake of Parnitha in 1999 (E5) *triggers* the rotational landslide that was observed along the road on the same day (E5). (fictitious)
- The explosion at the Montserrat massif in 2007 (E5) (near Barcelona, Spain) *triggers* the rock fall event (E5) which happened on 2007-02-14 (Vilajosana et al., 2008).
- The 1966 flood in Florence (E5) *triggers* mould growth on books (E5) stored in flooded library rooms (Rubinstein, N., 1966)

The SIG voted on the proposal. The examples are considered consistent with the current scope note and can be voted on (in their current form)

Outcome of the vote.

In favor: 9 (7 in person, 2 online)

Against: None

(15 participants abstained)

O15 occupied (was occupied by) reformulation

Proposal to reformulate the definition as follows:

- Take out the equivalence with *P156 occupies (is occupied by)* from the class declaration, on the grounds of consistency.
- Add a clause in the scope note stating the equivalence between the two properties
- Add an FOL axiom for the equivalence between O15 and P156, if the domain of O15 is restricted from S10 Material Substantial to E18 Physical Thing. (HW: CEO)

Details in the [appendix](#)

The SIG voted on the proposal.

Outcome of the vote.

In favor: 7 (3 in person, 4 online)

Against: None

(17 participants abstained)

O17 generated (was generated by) – unreferenced example

- The introduction of my copper samples in the salt-spray apparatus (S17) *generated* new corrosion layers of cuprite and malachite (E18)

The example has been marked as fictitious, despite being documented in TV's PhD dissertation, which has not been published as a book.

Proposal: reference it as A.Velios (personal communication, DATE) or directly reference the Thesis.

HW to TV to provide the reference.

The SIG voted to approve the example

Outcome of the vote.

In favor: 9 (5 in person, 4 online)

Against: None

(15 participants abstained)

O18 altered (was altered by) –revise and approve examples

- The death of the trees caused by beetle infestation in 1995 (S18) *altered* the Brazilian forest (E18) (Paine, 2008).
- The application of tension (S18) *altered* the humidified parchment of the Lanhydrock Pedigree (E18) (Pickwood, 2010).

The SIG voted to approve the examples

Outcome of the vote.

In favor: 12 (9 in person, 3 online)

Against: None

(12 participants abstained)

EPISA – Entity and Property Inference for Semantic Archives

Inês Koch, Carla Teixeira Lopes, Cristina Ribeiro, Sérgio Nunes. Link to presentation [here](#).

Issue 364: Create Profile Markup Language/Schema/ Ontology Profiles (continuation)

Zeljij: A semantic pattern development and documentation system (Presentation by George Bruseker).

Link to presentation [here](#)

HW: in principle there needs to be some agreement with respect to the exchange format of the identified patterns. GB to provide details of the patterns he has documented so far. FB, AG can also participate in this.

Issue 351: Modelling Principles

EC has collated all “last edited” versions of the Modelling Principles documents, into a new document ([v0.2](#)) that can be accessed through the CIDOC repo and through the CRM website under [Resources\Technical Papers\Principles for Modelling Ontologies: A Short Reference Guide](#).

Proposal:

- Accept the collated version by EC as the basis for the official one.
- Then task the people involved in this to resolve any comments left open, and
- Publish the document in its final form and advertise the fact.

The SIG voted on the proposal

Outcome of the vote.

In favor: 16 (10 in person, 6 online)

Against: None

(8 participants abstained)

Decision: The SIG will decide at the next meeting how to advertise this text as a best practices document (i.e. through which channels), when the comments will have all been resolved.

587 WD: Principles for Modelling Ontologies: A short reference guide (intro and examples)

AK & PF presented HW to the SIG, namely: the set of research questions collected in the course of the project SeaLiT, that were provided by project partners as things they would like to query the available data sources about; and the formalization of these research questions in a graphical query style that could be directly translated into SPARQL queries.

This resource demonstrates how the questions relate to the ontology developed, and that the ontology is adequate to query the data for these things. It is relevant as a methodological tool for bottom-up modelling. They should appear as examples complementing the introduction of the Modelling Principles that now stands alone as a quick reference guide (see CIDOC CRM site, under Resources\Technical Papers).

A parallel work was reported by AG for the Notre Dame restoration project that she has been working on. These questions (in French) can be shared with the CRM SIG. AG plans to translate the questions in English and she wishes to present them at the SIG (in the fashion that AK & PF presented the research questions collected in the context of SeaLiT)

Proposal:

- Offer a provenance statement for the SeaLiT research questions and the queries (PF & AK)
- Publish collections of research questions as a resource for the CIDOC model. People can look at the research questions that have motivated the development of the ontology.
- SEALIT research questions to appear on the site (according to the decisions of issue 601). Link them to:
 - The short reference guide (Intro to Modelling Principles)
 - the consolidated Modelling Principles document that Erin put together

The SIG voted on the proposal

Outcome of the vote.

In favor: 13 (9 in person, 4 online)

Against: None

(10 participants abstained)

Decision: Proceed as proposed.

HW assignments:

- **AK & PF:**
 - provenance statement for research questions provided by historians in the context of SeaLiT
 - selection of a subgroup of research questions and graphical queries to be explained (in a digestible format)
 - eventually put the SPARQL queries on the site.
- **AG:** supply research questions provided by conservators/architects in the context of Notre Dame de Paris restoration (French and English, provenance statement)

Issue 533: How to disambiguate polysemous concepts used as ontological classes

MD presented HW undertaken together with AF & FM, on polysemous concept disambiguation – through the definition of distinct ontological classes. Example from epigraphy –polysemous term “inscription”.

Proposal to incorporate current [HW](#) in the Principles for Modelling Ontologies (the collated version by EC) and to add some graphics to it (**HW** to AF, MD, PF)

The SIG voted on the proposal

Outcome of the vote.

In favor: 12 (7 in person, 5 online)

Against: None

(12 participants abstained)

Decision: As proposed. Retrofit this to issue 351.

HW: EC, MD (for 351);

HW: AF, MD, PF (for the graphics)

Issue 601: publish research questions on the website

HW presented by FORTH.

Proposal for a new link on the site where methodological documents should appear under. Details (mock-up for methodology landing page) [here](#).

Discussion points:

- The scientific research questions are an empirical source in support of the methodology observed. This is not evident from lumping together all sorts of methodological documents and not specifying how they should be used or what purpose they serve.
- Either have a separate subsite just for scientific research questions and a separate one for methodology, or if they are both found in the same page, then they should be separated by some delimiter –could be a horizontal line in a tabular representation.
 - Splitting up the page in two and adding a subtitle to the research questions bit along the lines of: “Research questions in support of the methodology for modelling ontologies” could do the trick. This way, navigating the site does not become way too complicated through the addition of multiple links.
- An overall text that describes what Methodology is about is needed too.
- “Presentation date” is plainly wrong for Dissertations, published papers etc. It should either be Release Date or just Date. Needs to be checked for all the resources published on the site.

Way to move forward:

- FORTH to present a new mock-up link under Methodology, where the empirical data in support of the methodology (a.k.a. “Scientific research questions”) will appear separate from the guidelines for bottom-up modelling.
 - Add to this set the questions used in the Notre Dame restoration project –supplied by AG (see issue 587).
- FORTH to reconsider the “Presentation Date” labels that are used throughout the site

Issue 624: Add E33_E41_Linguistic_Appellation to the Official Specification

The SIG reviewed the proposal by GB & RS to introduce class Exxx Name into the CIDOC CRM specification, as the equivalent of the E33_E41_Linguistic_Appellation that has been minted for the rdfs implementation. Proposed class declaration in the [appendix](#).

Discussion points: The proposal spurred a lively debate concerning the utility of such a class – two lines of argumentation formed:

- Held by GB, EC, (RS through the mailing list)
 - Treating (people’s/places’/...) names on a par with E35 Title in the sense that despite their typical lack of a propositional meaning, names do stand in a similar relation to language as titles do, namely single out individuals from a similar set of things, identify unique individuals, are arbitrarily assigned (for the most part).
 - Since P72 has language connects all instances of E33 Linguistic Object to the E56 Language they are expressed in, and this works well with instances of E33 Title (for which it holds IsA E41 Appellation), the same could hold for the instances of Exxx Name –names should also get attributed a language.
 - The guideline in the scope note of E41 Appellation instructs to document the language of the appellation through P72 (for NPs, which <proper> Names are, by default). The practice is also applied in the rdfs through E33_E41_Linguistic_Appellation, it needs to make its way to the official documentation.
- Held by MD, PR, FB
 - It is not the Appellation that has a language but the association of a name/appellation with an individual object. This is captured through the semantics of F12 Nomen in LRM, and F12 Nomen is explicitly NOT an instance of E41 Appellation.
 - It is not clear what a name being expressed in a given language signifies: what does “being expressed in a given language” mean? Is it the writing system that determines the appropriate language/linguistic group? Spelling variations? Phonetic rendering/indications? The proposed scope note does not specify it. Also, when it comes to spelling variations, they could represent dialectal variation within one and the same language.
 - Alternatives have been proposed, i.e., instead of using P72 opting for a more explicit statement like “uses language”/“is expressed in language”

The ordering by which contradictory principles (should) apply was also contested –namely,

- (i) **it was argued that** the class should not be admitted since it does not come with a set of properties connecting it to other classes –which seems to indicate that it is a form of classification, not ontology (principle 3.1 violation), **but also**
- (ii) that properties should not be repeated, and as such one can connect all subclasses through the superproperty –i.e., there is no need to implement yet another property that IsA P72 has language (which would yield a principle 2.3 violation).

Way to move forward: Since there is no way to resolve this issue if all principles rank the same, **HW** assigned to MD to formally make a counter-argument, cast in terms of a strict example showcasing logical problems that ensue from admitting class Exxx Name into CIDOC CRM. This way, the SIG will

make an informed decision, either dispensing with it or altering the proposal seeing that it does not create the type of logical problems that were alluded to.

Issue 594: Semantically replacing Recording Event and Externalization Event

The SIG reviewed HW by MD (redrafting of proposed new property for LRMoo *Rnn* included a memory of [D: F28 Expression Creation, R: E7 Activity]). The details of the proposal can be found in the [appendix](#).

Discussion points:

- The property works differently than what has been the common practice in the CRM, where typically the association is between a thing/concept and its creation, not between an activity and the influence it had in the creation of another thing/concept.
- LRMoo group would prefer it if the property was at F1 Work level, not an activity. The first Expression Creation (F28) is rarely documented, in that sense, the F1 Work is the appropriate level for this property to point from. They envisioned something along the lines of P62 depicts but a bit generic, in the sense that it has to cover recordings too.

How to proceed:

- LRMoo group are skeptical about the proposed property, and think it's premature to vote on it.
- HW: PR, TA, MZ to look at it some more and make a counterproposal. Ask MD for feedback.

Issue 547: CRMdig update

GB brought the SIG up to speed with the current state of CRMdig. Following the decision to deprecate a number of classes and properties violating principles or common practices (documented in issues 618, 619), he and VA loaded the last edited version in OntoME and implemented the decisions (class/property deprecations) and issued a new release (v4.0), that is currently on the [site](#).

So far 3 modeling clusters identified as clashing with CRMbase 7.1.1 –to be reviewed by the SIG:

- a) D13 Digital Information Carrier
- b) D9 Data Object
- c) Annotation classes [D29 Annotation Object, D20 Annotation Event, D35 Area]
- d) Overall scope of the model –old statement, explicit mention to a project that is no longer relevant.

D13 Digital Information Carrier (superclass not defined in CRMbase)

Following the deprecation of E84 Information Carrier in CRMbase, D13 needs to be assigned a different superproperty.

Discussion points: Alternative to the proposal by GB: instead of keeping D13, one could subtype an instance of E22 Human-Made Object. P2 has type: E55 Type {"hard drive"}. But a digital carrier would be substantially different from something that can carry analog information (tape recorders, writing on a paper etc.); it is intended for instances of D1 Digital Object alone. Also, there is a property pointing from D13 to D1 that cannot be substituted by another property in CRM.

Proposal: make D13 IsA E22 Human-Made Object

Proposal I: Leave as Is, Just Place under E22

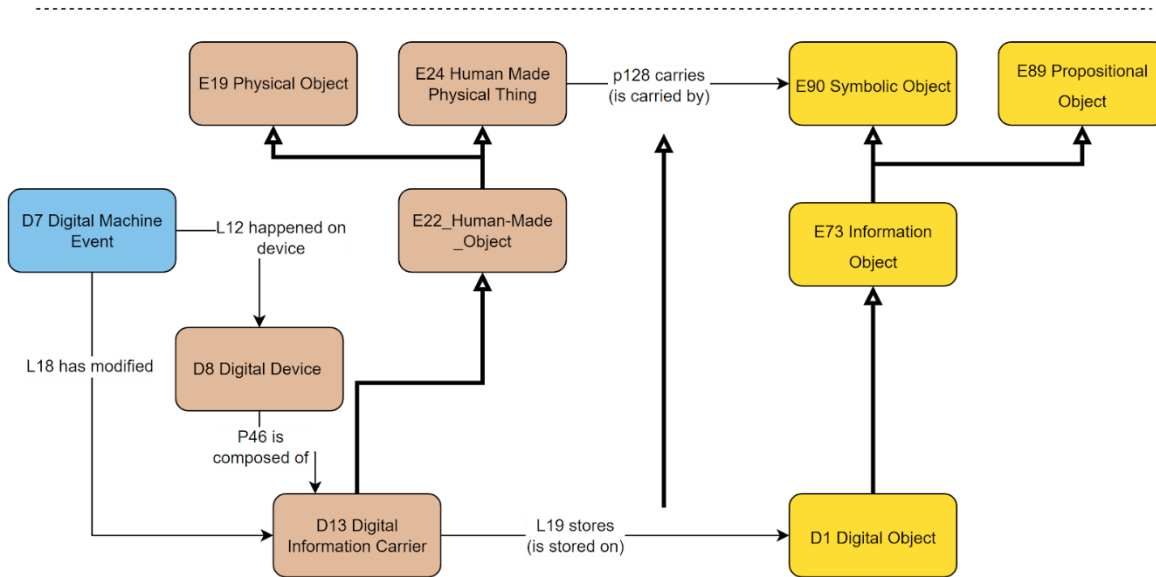

The SIG voted on the proposal

Outcome of the vote.

In favor: 9 (8 in person, 1 online)

Against: None

(15 participants abstained)

Deprecate D9 Data Object –express the concept it through property Lxx encodes dimension [D: D1 Digital Object, R: E54 Dimension]

Discussion points: identity conditions for dimensions and digital objects are incompatible. Neither multiple inheritance nor multiple instantiation should be permitted when the identity conditions of the classes at hand are incompatible.

Proposal: replace D9 with this “encodes dimension” property. Does not come with a ready-made scope note and label for the property, it just documents the intention to deprecate the class and substitute it by a property.

Proposed State I:

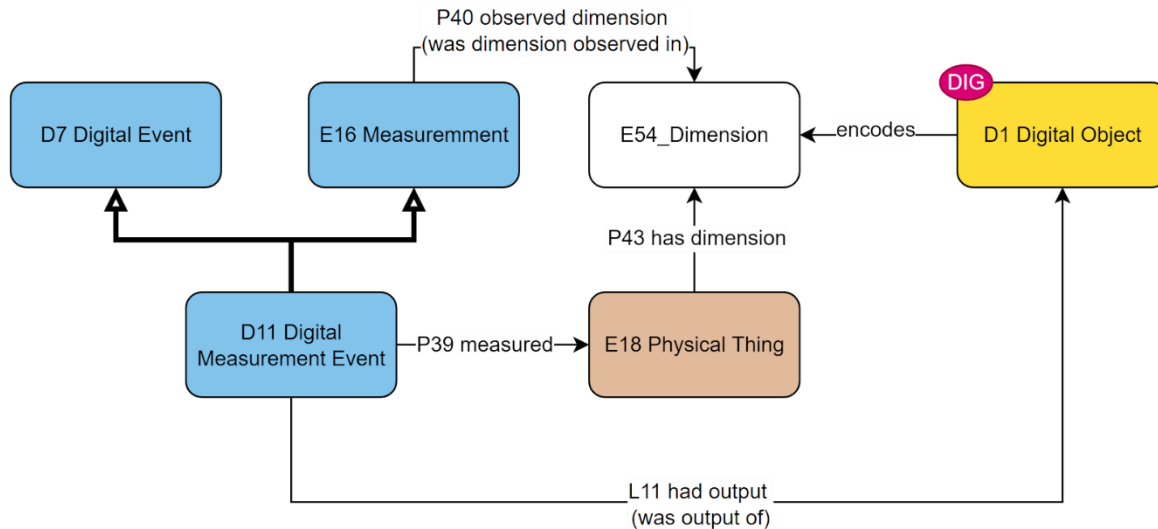

The SIG voted on the proposal

Outcome of the vote.

In favor: 12 (8 in person, 4 online)

Against: None

(12 participants abstained)

HW: GB to draft the definition of the property.

Annotation models – deprecate

Problems with annotation classes listed below:

- D35 Area (IsA D1 Digital Object AND IsA E26 Physical Feature), which is ontologically impossible. Proposal to deprecate it and reconsider what happens to the properties L49 and L50.
- D29 Annotation Object (relates to argumentation based on its semantics) and D30 Annotation Event do not fall in scope with CRMdig – should move to a different model (CRMInf)

Discussion points:

- For D35: the concept describes a section on a digital object. The software that visualizes digital objects (for the purpose of annotating them). This model here misses the association with a string encoding the “digital place primitive” information. The relation to E26 Physical Feature definitely has to be broken off.
- D29, D30: unwillingness to deprecate. They have reportedly been used in projects. Better decide where to move them before deprecating them. An obvious candidate is CRMInf (discussion on named graphs)

Overall scope update

Rewrite the formal ontological description of the CRMdig, update the list of editors.

Discussion points: Not ready to change the status to Stable.

Editors: GB, MD, can ask NC, RS, and anyone else who has worked on it.

Decisions:

- Make D13 Digital Information Carrier IsA E22 Human-Made Object
- Deprecate D9, introduce Lxx encodes dimension
HW: GB to provide definition
- Make D35 ISA E26, add property (for association with a digital place primitive)
HW: MD to draft the property definition
- D29, D30 to be moved to CRMInf instead
- **HW:** Provide a new scope, name editors (MD, GB)

Friday 9 December 2022

Issue 482: CIDOC CRM interfacing risk assessment in conservation

TV presented joint HW with DF, MA, GB, AG where they proposed definitions for CR1 Vulnerability Assessment, CR2 Vulnerability Belief and associated properties [represented in the [diagram](#)]. The proposed scope notes for [CR1 Vulnerability Assessment](#) and [CR2 Vulnerability Belief](#) can be found in the appendix. The scope notes for the associated properties were not further discussed. The modelling constructs should first be reexamined (take more examples of qualitative characterizations for vulnerability beliefs into account), before the SIG is presented with scope-notes for the properties.

Discussion points:

For CR1 Vulnerability Assessment:

it seems worth to look at insurance data and models, in the sense that most CH institutions are insured, and so are their collections. To offer quotas, insurance companies should be able to calculate the risks of having to compensate for objects/buildings, and to do that, they probably recourse to some vulnerability metrics. It would be interesting if this kind of data could be mapped against the modelling constructs proposed for CRMrisk. That the financial aspect is only a byproduct where CRMrisk is concerned, does not mean that insurance data should not be used to validate it, insofar as they make claims concerning the vulnerability of insured objects.

- In terms of “scope note writing guidelines”: a clause to be added to indicate the begin and end conditions for a vulnerability assessment.
- The examples should be referenced.

HW:

- TV to look for insurance data from CH institutions.
- TV to add the clause for the begin/end conditions of CR1 Vulnerability Assessment
- DF to provide references for the examples -if they were simplified to become more accessible, use the original ones, with references to a paper/database or other source, instead.
- SdS to do some editing in the phrasing once all points above have been concluded

For CR2 Vulnerability Belief

- No consensus regarding the necessity for the belief to point to a dimension. The belief stemming from the assessment could be a qualitative one.
- Modelling the E54 Dimension of the CR2 Vulnerability Belief as a part/member of an instance of I4 Proposition Set (where statements are made regarding the numeric value and the type of vulnerability for the instance of E24 Physical Human-Made Thing the belief is about) was contested.
- The relation of the proposed *PR1 ascribed to J4 that* is contested was considered to be either IsA or shortcut.
- Before deciding on PR1 the group working on CRMrisk need to review more examples (including qualitative ones –to be supplied by AG).

HW: DF, MA, TV, AG, AK to discuss the modelling constructs around CR2 Vulnerability Belief and PR1 ascribed some more. Arrange a meeting among themselves and come back with a new, revised proposal to the SIG.

Issue 488: Modelling an Actor carrying out an action at the Behest of Another

The SIG reviewed [HW](#) by GB –a proposal about subtyping P14.1 in the role of –using Speech Act Patterns. For details see link.

Discussion points:

- Architectural data corroborates this modelling option, it seems. Upon designing a building for a client, an architectural firm may be in direct contact with another group of architects who have been delegated with acting on behalf of the client (making all the executive decisions for them). AG can provide data representing this information.
- The modelling constructs referred to (speech acts, institutional facts, etc.) relate to CMRsoc, in which there has been no progress in a while now. It seems unlikely that a solution presupposing agreement on concepts that have not been accepted, will be agreed upon by the SIG.
 - The alternative is to close the issue and revise it once CMRsoc has been addressed and decided upon.
 - In the meantime, anyone wanting to share data with GB, can do so.

Issue closed

Issue 557: Which family model should classes (i) Provision and (ii) Business Obligation appear under?

The SIG was brought up to speed with the current state of the issue, namely:

- AK, PF have provided MD with material from SeaLiT and Spectrum that showcase the bottom-up development of CRMcom
- MD has drafted a scope for CRMcom based on this (and possibly other) material

However, since MD was not present at the session, the way to move forward with this is to document who is interested in working with MD (and AK, PF, DO) on CRMcom. The focus of CRMcom lies more on contracts and financial transactions.

Discussion points:

- The proposal to vote on the scope of the model was essentially vetoed by TV, on the grounds that CRMsoc on the one hand, and contracts/financial exchanges that form the core of CRMcom on the other, are very close to one another. Before voting on the scope for CRMcom the SIG should resolve on CRMsoc. GB, FB, MD should all be present for the SIG to reach a decision
- AG has volunteered to work on CRMcom as well

Issue 481: scope notes for socP21 and socP22

TV walked the SIG through the issue. It involves renaming CRM properties *actP22 specifies time-span (is specified time-span of)* and *actP21 specifies place within (is specified place of)*, that connects an event template to the timespan and place it is included in/occurs at.

MD had made a proposal to introduce another property for places overlapping with that of the event template. TV thinks that this is far from ideal in the sense that:

- One can always use the CRM properties to designate all sorts of topological relations. No reason to duplicate all possible constructs in CRMact.
- Overlap is a prerequisite for relevance in CRMact. If at a later stage there is need to add a separate property to explicitly declare it, it can be done without problems. The same thing applies to broadening the scope of or *actP21 specifies place within*.

Proposal:

- relabel properties actP21/actP22 into
 - actP21 specifies place within (is contained place specified by)
 - actP22 specifies time-span within (is contained time-span specified by)
- do not introduce an extra property that documents the overlap of the place specified by the event place and the space that the event that matched the template occurred in. For the moment, these relations can be drawn from CRMbase.

The SIG voted to relabel actP21/actP22, against the introduction of a new property.

Outcome of the vote.

In favor: 11 (6 in person, 5 online)

Against: None

(7 participants abstained)

Decision: as proposed

Issue closed

Reschedule the 57th CIDOC CRM SIG, 50th FRBR/LRMoo SIG & ISO/TC46/SC4/WG9 Meeting Proposal to change hosting organization for the autumn meeting of 2023. It was decided earlier on that it would take place on the 10-13 October 2023 at FORTH, however AG who has recently changed affiliation (CNRS/MAP), informed the SIG that Livio De Luca (director of CNRS/MAP) is willing to host the SIG for that meeting.

No objection, neither from FORTH, nor from any other participant.

Issue 623: Editorial check of CRMsci examples (continuation)

O19 encountered object -replace fictitious example

- The preservation followed the in situ finding (S19) that *encountered object* 18 arrowheads (E18) from Lerna in Argolis in 1994 (fictitious)

Discussion points:

- The preservation event is extraneous to the property and should be omitted.
- CEO can provide an example from a Viking ship excavated in 1911
- It is weird for “in situ” to characterize the encounter event. It’s more closely related to the preservation event -hence irrelevant for the example as it is.

HW: CEO

O20 sampled from type of part – examples review

- The sampling (S2) of tissue for DNA analysis of human remains in an archaeological site, sampled from type of part molar tooth (E55 fictitious).
- The sampling (S2) undertaken by Joyce Plesters in June 1963 while she was working on the painting ‘Cupid complaining to Venus’ (Cranach), sampled from type of part paint (E55). (The National Gallery, London, 1963)

The SIG voted to approve the examples.

Outcome of the vote.

In favor: 9 (5 in person, 4 online)

Against: None

(9 participants abstained)

O21 encountered at (witnessed encounter) -add new example -discuss FOL

- The current example has no references to it, CEO will reformulate the example he provides for O19 encountered object to match the semantics of O21.
- The property declaration contains some difficult to read FOL axioms, which have also been rendered into natural language statements. The statements have been introduced in the FOL section, but that’s a new one –nowhere else in the CRMbase and/or compatible models have we introduced suchlike expressions.
 - $O21(x,y) \Rightarrow (\exists z)[E53(z) \wedge P161(x,z) \wedge P89(y,z)]$: There exists a place z which is the spatial projection P161 of the encounter event S19, and contains P89i the place of encounter.
 - $O21(x,y) \Rightarrow (\exists z,v,w)[E93(w) \wedge E18(z) \wedge E52(v) \wedge O19(x,z) \wedge P195(w,z) \wedge P4(x,v) \wedge P164(w,v) \wedge P197(w,y)]$: The presence E93 of P195 the encountered object O19 at the time E52 of P4 the encounter P197 covered parts of (or P167 was within) the place of encounter.

Discussion points:

- Issue [570](#) discusses FOL re-expression into natural language. CEO and TV to propose a way to describe this (and a template for future possible uses).
- Since there is an unresolved issue about re-expressing FOL statements, the proposal is to remove the statements from CRMsci v2.0 and reintroduce them (probably in the text of the scope note) as determined by 570. See [minutes of 52nd CIDOC CRM SIG meeting](#) (p.7-8) for the current state of affairs. It is a recurrent problem (ensuring that class/property definitions are

uniform throughout the CRM family models –also check **Overall Comments** section for Issue 588 ([55th CIDOC CRM SIG meeting](#)).

HW: CEO to provide the example and (together with TV) to reconsider the place of the FOL axioms expressed in natural language –relates to issue [570](#) and issues [494](#) (guideline for writing scope notes) and [384](#) (template for [family models](#)).

O23 is defined by (defines) –reformulate and approve example

Proposal to reformulate the example into (changes in blue):

- The accumulation zone (S22) of the landslide *is defined by* the evolution of the landslide of Santomerion village in 2008 ([E92](#)) (Litoseliti et al., 2014).
- The example used to be (v1.8):
[This google earth image marks in red](#) the accumulation zone (S22) of the landslide *which is defined by* the evolution ([E92](#)) of the landslide of Santomerion village in 2008 (Litoseliti et al., 2014).

The SIG voted to approve the example.

Outcome of the vote.

In favor: 6 (3 in person, 3 online)

Against: None

(12 participants abstained)

O25 contains (is contained in) -add example

The example is missing, CEO, AG tasked with providing one from excavation data, or geology: a stone embedded in some other material.

HW: CEO, AG to propose an example for this. Put it up for an evote

O28 is conceptually greater than –approve example

Proposal to approve example below:

- In the condition survey of the manuscripts of the library of the Saint Catherine Monastery, the option ‘supple’ (E55) *is conceptually greater than* the option ‘stiff’ (E55). [These options are used for assessing parchment on page 2, section 2 of the survey form and within the context of the dry conditions of the Sinai desert where the Monastery is, ‘supple’ is considered better because it is less brittle] (Pickwood, 2004)

Discussion points:

- The scale is context-specific. It’s potentially counterintuitive to uniformly represent characterizations of situations that lie on the positive (or simply non-negative) end of a spectrum as “conceptually greater than”. If the variable at hand is “Fire Danger Forecast” then “Extreme” is conceptually greater than “Very Low”, but it’s definitely not better. An evaluation of the represented situation (in a good-bad scale) should not be part of the relation of the ordinal values. In the example listed, one needs to first map the values ‘supple’ and ‘stiff’ to evaluation of a condition state, before one understands what the scale is.

The SIG voted to approve the example.

Outcome of the vote.

In favor: 7 (3 in person, 4 online)

Against: None

(11 participants abstained)

Overall issue for v2.0 that's still pending

The Present tense marking on O13 triggers (is triggered by). MD to indicate whether this is on purpose or a misnomer. See issue [620](#) above.

Issue 549: revise TX5 Reading versus TX6 Transcription

PF presented the updated model (following decisions in the 54th CIDOC CRM SIG meeting in Rome and harmonization with CRMbase v7.1.2)

Subtopics discussed:

TXP16 employs script –approve scope note and examples

Details of the proposal in the [appendix](#).

Discussion points:

- The examples were edited to temporally and semantically restrict what is meant by “the Latin script” –seeing as it has evolved over the centuries. The examples were valid despite what version of the Latin script was referred to, but the participants felt it to be clearer in this form.

The SIG voted to approve the definition (and examples).

Outcome of the vote.

In favor: 10 (6 in person, 4 online)

Against: None

(8 participants abstained)

TXP7 has item (is item of) –proposed property definition

Proposal: Following the change of its domain class, the scope note needed to be amended. For details of the proposal see [appendix](#).

Discussion points:

- The scope note defines the inverse property
- The phrase “the instance of TX13 Script in which it is *referred*” is cryptic and its meaning is disputed.

An effort was made to redraft the scope note in the right direction and using another verb but it was unsuccessful.

HW: AF, FM to revisit this.

TXP17 has part (forms part of) – proposed property definition

Proposal: approve property definition TXP17. Details of the proposal in the [appendix](#).

Discussion points:

It is understood that the “Note” clause in the scope-note is intended to illustrate how the property is inherited to its subclass (namely TXP11 Grapheme Occurrence), but it needs to be stated more explicitly.

I.e., the scope note should explain what it means for an instance of grapheme sequence to form part of a broader sequence, and after having determined the TX11 IsA TX12 relation, then mention the specific case of an instance of TX11 Grapheme Occurrence to form part of another instance of TX11 Grapheme Occurrence (exemplified by the composite symbol formerly used for “ü” in German).

For the missing example: copy off any randomly picked subpart of an inscription example to showcase the typical use of the property (‘Caesari’ has part ‘aesari’ sort of thing). As it stands now, it only exemplifies the marginal case.

HW: AF, FM to revisit this and then call for an e-vote

TXP18 read (was read by) – proposed shortcut property definition

Proposal: approve property definition TXP18. Details of the proposal in the [appendix](#)

Discussion points:

- “complete linguistic meaning” imposes a complete-world assumption. Might be the case for the Derveni papyrus, but needn’t always be the case.
- “read and interpreted” in the example: the name of the property is read. Not interpreted. Best add that as a comment at the end of the example.
- “interpreted” did not resonate well with participants. Why not “understood”? EC and PF to further communicate about this.
- Scope note needs editing to reflect that it is the linguistic meaning of the linguistic object that is carried by the physical thing that the TX1 Written Text (IsA E25) is.

HW: AF, FM to revise this and then send out an e-vote

Deprecate TXP3 rendered

The property has become obsolete, it has been substituted by the path via TX12 Grapheme Sequence

The SIG voted to approve the full definition and examples.

Outcome of the vote.

In favor: 7 (5 in person, 2 online)

Against: None

(11 participants abstained)

Review proposed examples for TXP14, TXP15, TX12

TXP14 used copy or representation of (was deciphered via copy or representation)

The non-autoptic recognition of the inscription text on the Arch of Constantine (TX5) *used a copy or representation* of the written text (TX11) on the Arch of Constantine [performed using a photo of the arch].

The SIG voted to approve the.

Outcome of the vote.

In favor: 8 (6 in person, 2 online)

Against: None

(10 participants abstained)

TXP15 recorded correspondence (was recorded by)

The autoptic investigation carried out by Rodolfo Lanciani (TX5) recorded correspondence the grapheme sequence 'INSITICTV DIVINITATIS' on the Arch of Constantine (TX12).

The SIG voted to approve the example.

Outcome of the vote.

In favor: 9 (7 in person, 2 online)

Against: None

(9 participants abstained)

TX12 Grapheme Sequence

the grapheme sequence 'INSTINCTV DIVINITATIS' (TX12) [as recognized by the autoptic investigation of the Arch of Constantine, carried out by Rodolfo Lanciani]

The SIG voted to approve the example.

Outcome of the vote.

In favor: 8 (6 in person, 2 online)

Against: None

(10 participants abstained)

FOL proposals for TXP10/TXP14 and TXP13

A proposal to add FOL statements to properties TXP10/TXP13/TXP14 restricting the conditions under which they should be deployed.

- (a) Proposed axiom for TXP10 deciphered text: $\text{TXP10}(x, z1) \wedge \text{TPX14}(x, z2) \Rightarrow \text{P130}(z1, z2)$ (and in prose: If the text recognition process deciphered a text (TXP10) making use of a copy or representation of an original written text instance (TXP14), then the copy used in the deciphering process shows features of the original written text.)
- (b) Proposed axiom for TXO14 used copy or representation of: $\text{TPX14}(x, z2) \wedge \text{TXP10}(x, z1) \Rightarrow \text{P130}(z2, z1)$ (and in prose: If the text recognition process deciphered a text (TXP10) making use of a copy or representation of an original written text instance (TXP14), then the copy used in the deciphering process shows features of the original written text).

Discussion points: not easy to grasp why the statement about the replica (that it bears features of the original written text) is dependent on the replica having been used in a text recognition scenario and not the other way round. In the sense, that for a replica to show features of the original is a presupposition for it to be used for text recognition purposes.

It is a stretch to make assumptions on the quality of a replica based on the fact that it was used, but the material implication it is valid, just complex.

The SIG voted to approve the FOL statement, and also introduce it in prose to make it easier to understand.

Outcome of the vote.

In favor: 7 (5 in person, 2 online)

Against: None

(11 participants abstained)

- (c) Proposed axiom for TXP13 deciphered via representation: $TXP13(x, y) \Rightarrow (\exists z) [TXP14(x, z) \wedge P138(y, z) \wedge \neg TXP10(x, z)]$ (and in prose: If the text recognition process deciphered via a representation of the original text (a visual item), then there is a written text 'z' whose copy or representation was used in the text recognition process (TXP14), and the visual item represents the written text (P138), and the text recognition process did not decipher the written text through an autoptic investigation.)

Discussion points: the axiom serves to distinguish cases of autoptic vs non-autoptic investigation of an object. It is valid, and also reflects common practices: if one is not working using the original source for something, then it is considered good practice to declare it. It's a well-intended closed world assumption.

There are instructions against using a particular property in n CRMbase that are not combined with a similar FOL statement (f.i., P199 vs P138, and P67 vs P128). If this is a practice we're considering to adopt, then we risk infinitely multiplying the FOL statements across all models with instances of where to not use such and such property.

Postpone reaching a decision. The only point of controversy is the negation part. Everything else seems fine.

HW: CRMtex editors to revise and send out on an e-vote.

Overall editorial comment for CRMtex editors

Decide on the spelling –it can't be both 'autoptic' and 'auto-optic'. Preferably opt for the former.

Summary of decisions

The CRM SIG:

- Approved the definition of TXP16 employs script
- assigned HW to AF & FM to redraft the definitions of TXP7 has item, TXP17 has part, TXP18 read and send them out on an e-vote
- approved the deprecation of TX3 rendered
- approved the examples for TXP14 used copy or representation of, TX15 recorded correspondence, TX12 Grapheme Sequence
- approved the proposal for the introduction of an FOL axiom (also rendered in prose) for TXP10 deciphered text and TXP14 used copy or representation
- avoided reaching a decision on the introduction of an FOL axiom (also rendered in prose) for TXP13 deciphered via representation. CRMtex editors to revise and send it out for an e-vote.
- avoided reaching a decision regarding the new numbered release.

APPENDICES

Appendix I – List of abbreviated names

AF	Achille Felicetti	MR	Mélanie Roche
AG	Anaïs Guillem	MvR	Muriel van Ruymbeke
AK	Athina Krtistotaki	PF	Pavlos Fafalios
CEO	Christian-Emil Ore	PM	Philippe Michon
EC	Erin Canning	PR	Pat Riva
ETs	Eleni Tsouloucha	RS	Ron Sanderson
FB	Francesco Beretta	SdS	Stephen Stead
FM	Francesca Murano	TV	Thanasis Velios
GB	George Bruseker	VA	Vincent Alamercery
GH	Gerald Hiebel	WS	Wolfgang Schmidle
MD	Martin Doerr		

Appendix II -Issues

588

Comment in the .1 RDF file where the relation between the CIDOC CRM and the PC module is stated

Since RDF does not provide a direct way to define properties of properties, we make use of ‘property classes’ as a reification method for encoding the below properties of properties of CIDOC-CRM 7.1.1 in RDF:

- P3.1 has type: E55 Type
- P14.1 in the role of: E55 Type
- P16.1 mode of use: E55 Type
- P19.1 mode of use: E55 Type
- P62.1 mode of depiction: E55 Type
- P67.1 has type: E55 Type
- P69.1 has type: E55 Type
- P102.1 has type: E55 Type
- P107.1 kind of member: E55 Type
- P130.1 kind of similarity: E55 Type
- P136.1 in the taxonomic role: E55 Type
- P137.1 in the taxonomic role: E55 Type
- P138.1 mode of representation: E55 Type
- P139.1 has type: E55 Type
- P144.1 kind of member: E55 Type
- P189.1 has type: E55 Type

The implementation is provided in a different RDF file (CIDOC_CRM_v7.1.1_PC.rdf). The file defines the property classes, the properties of properties, as well as a set of classes and properties needed by this reification method.

Usage example

We want to express the information that an activity (instance of 'E7 Activity') was carried out by an actor (instance of 'E39 Actor') and that the actor had a specific role while carrying out this activity. First, the activity instance is linked to the actor instance using the property 'P14 carried out by'. The P14 property has the property 'P14.1 in the role of: E55 Type' which allows expressing the role the actor had while carrying out the activity. So, the property class 'PC14 carried out by' is defined and used as the domain of the property 'P14.1 in the role of'. During data generation, an instance of 'PC14 carried out by' is created which is linked to: i) the domain of 'P14 carried out by' (an instance of 'E7 Activity') using the property 'P01 has domain', ii) the range of 'P14 carried out by' (an instance of 'E39 Actor') using the property 'P02 has range', and iii) a type (instance of 'E55 Type') using the property 'P14.1 in the role of'.

Below is an indicative set of RDF triples:

```
:painting_sistine_chapel
  a crm:E7_Activity .
:Michelangelo
  a crm:E39_Actor .
:painting_sistine_chapel
  crm:P14_carried_out_by :Michelangelo .
:instanceOfPC14
  a crm:PC14_carried_out_by ;
  crm:P01_has_domain :painting_sistine_chapel ;
  crm:P02_has_range :Michelangelo ;
  crm:P14.1_in_the_role_of :master_craftsman .
:master_craftsman
  a crm:E55_Type ;
  rdfs:label "Master Craftsman" .
```

584:

The scope-note of *AP29 discarded into* changed

FROM (OLD)

AP29 discarded into (was discarded by)

Domain: [A1](#) Excavation Processing Unit

Range: [S11](#) Amount of Matter

Subproperty of:

Quantification: many to many (0,n:0,n)

Scope note: This property identifies the S11 Amount of Matter (e.g. a heap) into which material from an A1 Excavation Processing Unit is discarded.

Examples: The Excavation Processing Unit excavating the Stratigraphic Volume Unit (2) [illustration 4] (A1) discarded into the waste heap of the excavation (S11)

TO (NEW)

AP32 discarded into (was discarded by)

Domain: [A1](#) Excavation Processing Unit

Range: [S11](#) Amount of Matter

Subproperty of:

Quantification: many to many (0,n:0,n)

Scope note: This property identifies the S11 Amount of Matter (e.g. a heap) into which material from an A1 Excavation Processing Unit is discarded.

The same instance of A1 Excavation Processing Unit may discard matter into multiple heaps, but also simply throw away the excavated matter without any order or export it to be deposited elsewhere, thereby breaking any close correspondence between the excavation and the deposit.

Examples:

The Excavation Processing Unit excavating the Stratigraphic Volume Unit (2) [illustration 4] (A1) *discarded into* the waste heap of the excavation (S11)

556

Text clarifying the scope of the proposed terms and vocabularies

The Functional Role of a Minimal Vocabulary

...to be used together with the CIDOC-CRM

The policy of the CRM is to restrict classes to those that appear as specific domains or ranges of CRM properties, because those properties structure the knowledge base and frequently appear hard-coded in the control-software, i.e., data entry, storage and access tools. Therefore they are of much higher priority for system interoperability than the classes without properties, which we model as instances of E55 Type, i.e. as data, as usual in conceptual modelling of databases since their conception.

Nevertheless, in certain cases the CRM makes important and non-obvious ontological distinctions of specialization of CRM classes without assigning specific properties to them. These may differentiate and specialize even substance and identity criteria in a way that has a bearing on the use of properties, as in the case of E10 Transfer of Custody: The kind of transfer of custody, i.e., either field collection, transfer from one keeper to another or loss, can be specified by E55 Type, and consequently the property associating the donor or the receiver will not be used.

These distinctions normally appear in the scope notes with a hint about the need for respective vocabularies. They further appear in examples. Finally, a series of classes have been deprecated because they did not need specific properties, but backwards compatibility would require that they be turned into clearly recommended instances of E55 Type.

Over the past 30 years attempts to harmonize and integrate vocabularies in the cultural heritage (CH) domain have widely failed. Rather, some vocabularies play a more important role, but specialized needs are too abundant to allow for a systematic integration, and volatile vocabularies are an important tool of research in all sciences and humanities.

Therefore, the CRM-SIG will recommend in a document separate from the CIDOC CRM definition only those terms that are regarded to be important for the above-mentioned ontological distinctions, and unambiguous enough to be fixed as standard. These may be linked or integrated as broader or narrower terms into vocabularies of the user's choice, in a way compatible with the meaning of the classes of the CRM where they will be used together.

The CRM-SIG may exemplify this on the base of the Art & Architecture Thesaurus (AAT) or the Backbone Thesaurus (BBT).

Further, CRM will recommend the use of some standard vocabularies for cases in which a good and comprehensive international practice exists, such as measurement units, country codes etc.

Terms agreed upon for deprecated classes

Deprecated Class	Migration Instruction	Type	Scope note
E45 Address	use E41 Appellation, P2 has type: "Address"	ID: 300386983 Page Link: http://vocab.getty.edu/page/aat/300386983 street addresses (geographic concepts, physical sciences concepts, ... Associated Concepts (hierarchy name))	AAT Note: Particulars of the place where a person, organization, building, or monument can be found on a street or other thoroughfare; typically consisting of a number, street name, the name of the administrative area (a town or district). May also include a postcode, as the street address may also be the "mailing address."

613:

CRMbase Candidates for WIS

In CRM base one can find the possible WIS by a text search '↔' or variants over 'implies'. Six of the shortcuts in CRM are of the form <the long path> is equivalent to <the shortcut property>. These are:

- P125 used object of type (was type of object used in),
- P156 occupies (is occupied by),
- P167 was within (includes),
- P171 at some place within,
- P172 contains
- P195 was a presence of (had presence)
- (P199?)

In addition, **P7** and **P156** implies a long path:

P7 took place at (witnessed):

Therefore, this property implies the more fully developed path from E4 Period through P161 has spatial projection, E53 Place, P89 falls within to E53 Place, where the intermediate place is also defined in the same geometric system.

P156 occupies (is occupied by):

This property implies the fully developed path from E18 Physical Thing through P196 defines, E92 Spacetime Volume, P161 has spatial projection to E53 Place.

(by the way the quantification (0,1:0,n) of P156 may be wrong here since "Therefore, there is a 1:1 relation between the instance E18 Physical Thing and the instance of E53 Place it occupies")

The following have implications in the FOL and imply the long path (for CRMbase)

P26 moved to (was destination of)

$P26(x,y) \Rightarrow (\exists z)[E53(z) \wedge P7(x,z) \wedge P89(y,z)]$

P27 moved from (was origin of)

$P27(x,y) \Rightarrow (\exists z)[E53(z) \wedge P7(x,z) \wedge P89(y,z)]$

P46 is composed of (forms part of)

$P46(x,y) \Rightarrow (\exists zw)[E93(u) \wedge P195i(x,u) \wedge E52(z) \wedge P164(u,z) \wedge E93(w) \wedge P195i(w,y) \wedge P164(w,z) \wedge P10(w,u)]$

P101 had as general use (was use of)

$P101(x,y) \Rightarrow (\exists z)[E7(z) \wedge P16i(x,z) \wedge P2(z,y)]$

P186 produced thing of product type (is produced by)

$P186(x,y) \Rightarrow (\exists z)[E24(z) \wedge P108(x,z) \wedge P2(z,y)]$

For CRMarchaeo

only one shortcut is declared and it doesn't have an FOL axiom:

AP21 contains (is contained in) is a shortcut for the more detailed path from E18 Physical Thing through *AP18i is embedded*, A7 Embedding, *AP19 is embedding in*, A2 Stratigraphic Volume Unit.

620:

NEW scope-note and FOL for O13 triggers (is triggered by)

Scope note:

This property associates an instance of E5 Event that triggers another instance of E5 Event with the latter. It identifies the interaction between events: an event can activate (trigger) other events in a target system that is in a situation of sustained tension, such as a trap or an unstable mountain slope giving way to a landslide after a rain or earthquake. In that sense the triggering event is interpreted as a cause. However, the association of the two events is based on their temporal proximity, with the triggering event ending before or when the triggered event starts.

In First Order Logic:

$O13(x,y) \Rightarrow E5(x)$

$O13(x,y) \Rightarrow E5(y)$

$O13(x,y) \Rightarrow P182(x,y)$

OLD scope-note and FOL for O13 triggers (is triggered by)

Scope note:

This property associates an instance of E5 Event that triggers another instance of E5 Event with the latter. It identifies the interaction between events: an event can activate (trigger) other events in a target system that is in a situation of sustained tension, such as a trap or an unstable mountain slope giving way to a land slide after a rain or earthquake. In that sense the triggering event is interpreted as a cause.

In First Order Logic:

$O13(x,y) \Rightarrow E5(x)$

$O13(x,y) \Rightarrow E5(y)$

612:

Figure 9: Classes and properties for describing measuring the position of things

Diagram for S23 Position Measurement

S23 Position Measurement

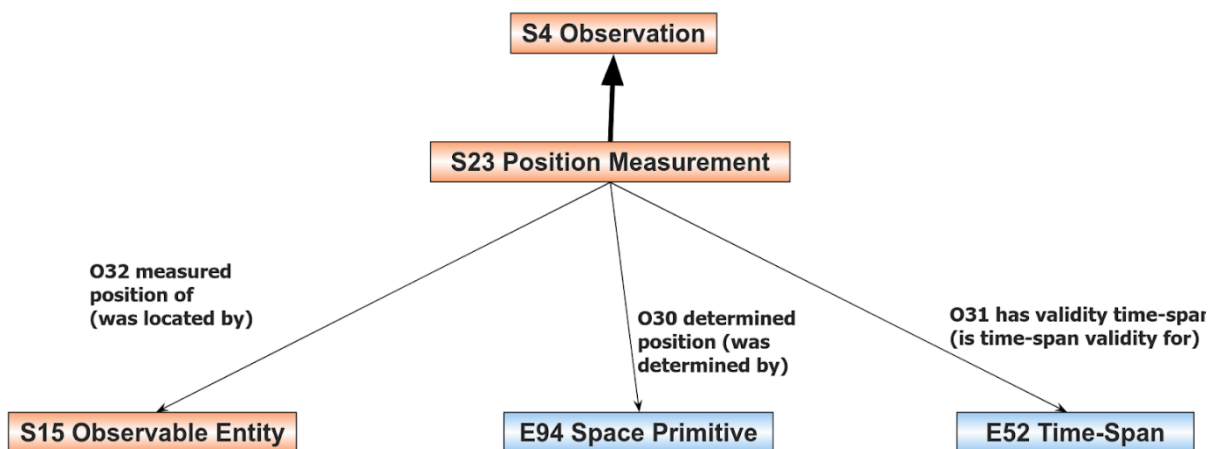

Figure 9: *Classes and properties for describing measuring the positions of things*

Accompanying text

Measuring positions

A specialisation of the class S4 Observation is the class S32 Position Measurement. It allows the modelling of the process of measuring the position of entities based on them being observed at a location in a given time-span. The properties connecting the observable entity with time and location are shown in Figure 9.

Figure 10: Example of position measurement of the Titanic after it hit an iceberg

Diagram for the example

S23 Position Measurement

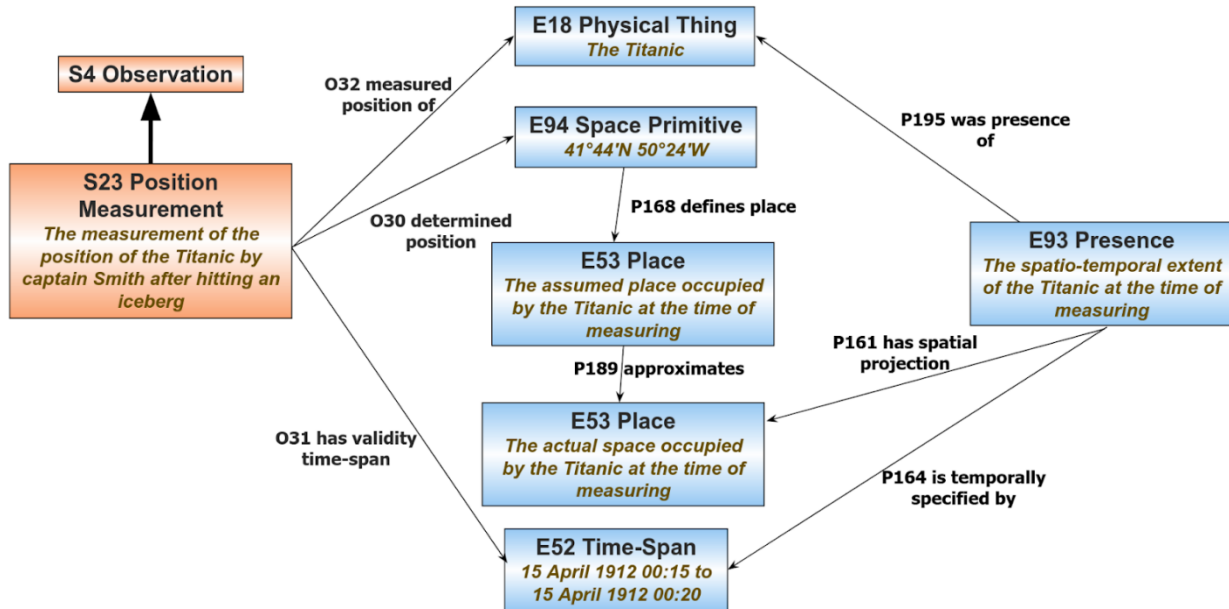

Figure 10: Example of position measurement of the Titanic after it hit an iceberg

Accompanying text

Figure 10 shows an example of measuring the position of the Titanic after it hit an iceberg. Before issuing a distress signal, Titanic’s captain Smith measured the position of the ship based on the distance travelled from the last known position, but this measurement was inaccurate. The Titanic is an instance of S15 Observable Entity and more specifically an instance of E18 Physical Thing and its spatio-temporal extent during measuring is an instance of E93 Presence. The spatial projection of this instance of E93 Presence is the actual place where the Titanic was after hitting the iceberg. Captain Smith’s measurement was inaccurate and the resulting latitude and longitude coordinates measured (instance of E94 Space Primitive) defined the assumed place of the ship and not the actual place. The assumed place is a separate instance of E53 Place which can only approximate the actual place. The two are connected with the property ‘P189 approximates’ which allows reasoning on different views of the location of things by comparing instances of E53 Place with their corresponding provenance.

611:

O30 determined position (was determined by)

Domain:

S23 Position Measurement

Range:

E94 Space Primitive

Subproperty of:

S4 Observation: O16 observed value (value was observed by): E1 CRM Entity

Quantification:

many to many (0,n:0,n)

Scope note:

This property associates an instance of S23 Position Measurement with the instance of E94 Space Primitive which is the result of that measurement. The instance of E94 Space Primitive approximates the place occupied by the entity whose position is being measured.

Examples:

- The measurement of the position of the Titanic by captain Smith after hitting an iceberg (S23) *O30 determined position 41°44'N 50°24'W* (E94) [This was quickly measured based on the distance travelled since the previous known location] (Tikkanen, 2022)
- The measurement of the position of the Titanic by officer Joseph G. Boxhall after the initial distress signal was sent (S23) *O30 determined position 41°46'N 50°14'W* (E94) [This was measured with more precision and revised the original position] (Tikkanen, 2022)
- The measurement of the position of the Titanic by Robert Ballard after the Titanic ship-wreck was found (S23) *O30 determined position 41°43'32"N 49°56'49"W* (E94) ('Wreck of the Titanic', Wikipedia, 2022)

In First Order Logic:

$O_{xx1}(x,y) \Rightarrow S23(x)$

$O_{xx1}(x,y) \Rightarrow E94(y)$

O31 has validity time-span (is time-span validity for)

Domain:

S23 Position Measurement

Range:

E52 Time-Span

Subproperty of:

E2 Temporal Entity: P4 has time-span (is time-span of): E52 Time-Span

Quantification:

many to one, necessary (1,1:0,n)

Scope note:

This property associates an instance of S23 Position Measurement with the instance of E532 Time-Span for which the measurement is valid. No inferences can be made in relation to the validity of the measurement outside this time-span despite the fact that some measured entities are relatively stable and their positions may remain the same after the measurement. The time-span of validity should fall within (*P86 falls within (contains)*) the overall time-span (*P4 has time-span (is time-span of)*) of the process of measurement.

Examples:

- The measurement of the position of the Titanic by captain Smith after hitting an iceberg (S23) *O31 has validity time-span* from 15 April 1912 00:15 to 15 April 1912 00:20 (E52) [This was only valid while the position was being re-measured] (Tikkanen, 2022)
- The measurement of the position of the Titanic by officer Joseph G. Boxhall after the initial distress signal was sent (S23) *O31 has validity time-span* from 15 April 1912 00:20 to 15 April 1912 02:17 (E52) [This was valid after the position was re-measured with more precision and was the measured position of the ship until the final distress signal was sent] (Tikkanen, 2022)

- The measurement of the position of the Titanic by Robert Ballard after the Titanic ship-wreck was found (S23) *O31 has validity time-span* 1 September 1985 12:48 (E52) ('Wreck of the Titanic', Wikipedia, 2022)

In First Order Logic:

$$\text{Oxx2}(x,y) \Rightarrow \text{S23}(x)$$

$$\text{Oxx2}(x,y) \Rightarrow \text{E52}(y)$$

$$\text{Oxx2}(x,y) \Rightarrow \text{P4}(x,z) \wedge \text{P86}(y,z)$$

O32 measured position of (was located by)

Domain:

S23 Position Measurement

Range:

S15 Observable Entity

Subproperty of:

S4 Observation: O8 observed (was observed by): S15 Observable Entity

Quantification:

many to one, necessary (1,1:0,n)

Scope note:

This property connects an instance of S23 Position Measurement with the instance of S15 Observable Entity whose position is being measured.

Examples:

- The measurement of the position of the Titanic by captain Smith after hitting an iceberg (S23) *O32 measured position of the Titanic* (E22) (Tikkanen, 2022)
- The measurement of the position of the Titanic by officer Joseph G. Boxhall after the initial distress signal was sent (S23) *O32 measured position of the Titanic* (E22) (Tikkanen, 2022)
- The measurement of the position of the Titanic by Robert Ballard after the Titanic ship-wreck was found (S23) *O32 measured position of the Titanic* (E22) ('Wreck of the Titanic', Wikipedia, 2022)

In First Order Logic:

$$\text{Oxx3}(x,y) \Rightarrow \text{S23}(x)$$

$$\text{Oxx3}(x,y) \Rightarrow \text{S15}(y)$$

Examples for S23 Position Measurement

- the measurement of the position of the Titanic by captain Smith after hitting an iceberg (S23) (Tikkanen, 2022)
- the measurement of the position of the Titanic by officer Joseph G. Boxhall after the initial distress signal was sent (S23) (Tikkanen, 2022)
- the measurement of the position of the Titanic by Robert Ballard after the Titanic ship-wreck was found (S23) ('Wreck of the Titanic', Wikipedia, 2022)

623:

Clause about the location of an S2 Sampling Activity (Introduction section, short description for Figure 3)

Sampling

The process of taking a sample can be described by the class S2 Sample Taking, a specialisation of the more general class S1 Matter Removal, as shown in figure 3. The activity of sampling removes matter from something and creates a new identifiable entity which can be described as an instance of the class S13 Sample. This is similar to the CIDOC CRM construct of removing parts from solid things through the class E80 Part Removal. CRMsci generalises this construct allowing sampling of fluids and other non-solid things. During sampling it is important to record the location on the sampled thing from where the sample was taken (e.g. collecting a pigment sample from the area of a canvas where an apple was painted). This can be described using the property O4 sampled at. This is distinct to the location that the sampling activity was taking place in general (e.g. the conservation studio where the sampling was done). **The location of the sampling activity contains the location from where the sample was taken. In contrast, during instances of S19 Encounter Event (see section on Observation below) the two locations are the same.** Partitive relationships between instances of S10 Material Substantial can be described using the property O25 contains, which generalises the CIDOC CRM property P46 is composed of used for solid things.

Diagram of S19 Encounter Event

Observation

[...]

The class S19 Encounter Event can be used to describe the observation of entities of particular interest relevant to the research study. This can be used in species surveys or finds in archaeological excavations. It serves documenting the fact that someone has seen the entity of interest as existing at the particular place and time. **Figure 8 shows the relevant properties and includes a set of instances as examples from the field of ecology.**

[...]

S19 Encounter Event

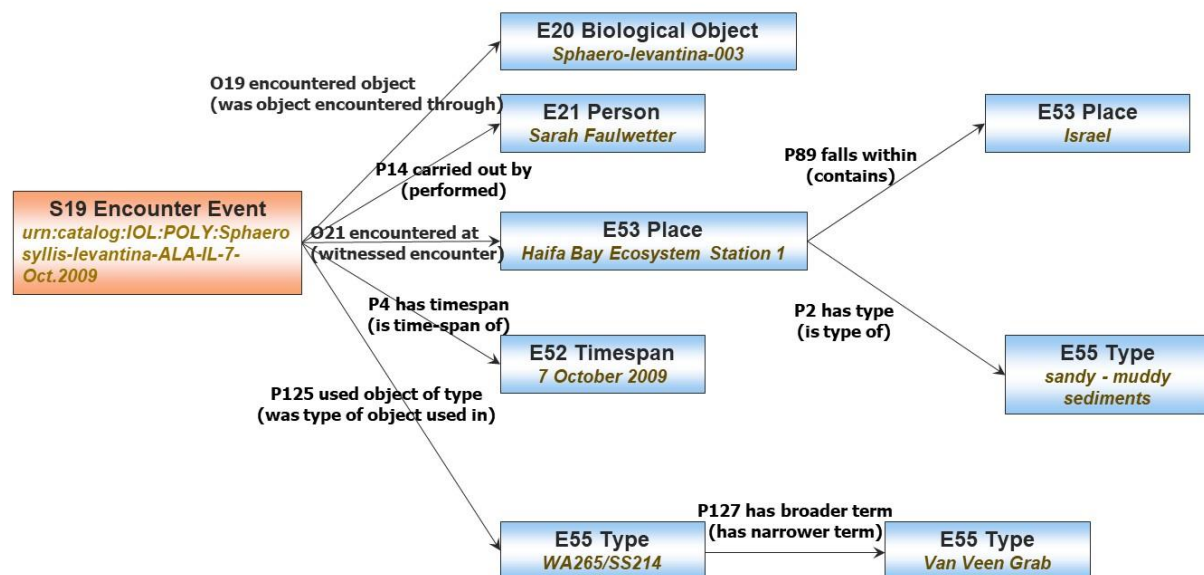

Figure 1: Classes and properties for describing the observation of an entity at a particular place and time.

Wrong inheritance from E16 Measurement in the scope-note of S3 Measurement by Sampling

Edit the inheritance, alter scope note:

To (NEW)

Scope note:

This class comprises activities of taking a sample and measuring or analyzing it as one unit of activity, in which the sample is typically not identified and preserved beyond the context of this activity. Instances of this class describe the taking of one or more samples regardless whether they are explicitly identified in documentation or preserved beyond this activity. The dimensions observed by the respective measurement of this particular sample are regarded as dimensions of the instance of S10 Material Substantial at the place from which the samples were taken.

Therefore, the class S3 Measurement by Sampling inherits the properties of S2 Sample Taking, O3 sampled from: S10 Material Substantial and O4 sampled at: E53 Place, and the properties of S21 [Measurement O24 measured: S15 Observable Entity](#). It needs not instantiate the properties O5 removed: S13 Sample and O24 measured: S15 Observable Entity, if the sample is not documented beyond the context of the activity.

From (OLD)

Scope note:

This class comprises activities of taking a sample and measuring or analyzing it as one unit of activity, in which the sample is typically not identified and preserved beyond the context of this activity. Instances of this class describe the taking of one or more samples regardless whether they are explicitly identified in documentation or preserved beyond this activity. The dimensions observed by the respective measurement of this particular sample are regarded as dimensions of the instance of S10 Material Substantial at the place from which the samples were taken.

Therefore, the class S3 Measurement by Sampling inherits the properties of S2 Sample Taking, O3 sampled from: S10 Material Substantial and O4 sampled at: E53 Place, and the properties of S21 [\(E16\) Measurement. P40 observed dimension: E54 Dimension, due to multiple inheritance](#). It needs not instantiate the properties O5 removed: S13 Sample and O24 measured: S15 Observable Entity, if the sample is not documented beyond the context of the activity.

O15 occupied (was occupied by) –reformulation of the definition

NEW

O15 occupied (was occupied by)

Domain:

[S10](#) Material Substantial

Range:

E53 Place

Scope note:

This property associates an instance of S10 Material Substantial with the instance of E53 Place that this substance occupied. It describes the space filled (occupied) by a physical matter. This property is the development of the shortcut expressed in the proposition of classification: “S20 Physical Feature” IsA “E53 Place”. [This property is equivalent to P156 occupies \(is occupied by\) with domain E18 Physical Thing and range E53 Place.](#)

Examples:

- The layer of pink plaster that *occupied* the block 30 floor of the area X. on 2009-02-03. [[The plaster covered the floor](#)] (fictitious)

In First Order Logic:

$O15(x,y) \Rightarrow S10(x)$

$O15(x,y) \Rightarrow E53(y)$

$O15(x,y) \wedge E18(x) \Leftrightarrow P156(x,y)$

624:

Exxx Name

Subclass of:

E33 Linguistic Object,

E41 Appellation

Superclass of:

E35 Title

Scope note:

This class comprises textual strings that within a cultural linguistic context are identified as names belonging to one or more languages. Being a subclass of E41 Appellation and E33 Linguistic Object, Exxx Name should be used when there is a need to document both a name and the language or languages in which it is identifiable.

Instances of Name can be given to anything by anyone who is a sentient user of language or a group which is attributed as having such powers.

594:

Rnn included a memory of (has been represented by)

Domain: F28 Expression Creation

Range: E7 Activity

Quantification: (0,n;0,n)

Scope Note:

This property associates an instance of F28 Expression Creation with an instance of E7 Activity that has been documented or represented completely or partially in the instance of F2 Expression created by the domain instance of this property. The documented or represented aspects of the associated activity should be the result of physical witness or mechanical recording by the creator of the respective Expression and be rendered or referred to in a more or less realistic form.

Typical examples are video or sound recordings of performances, traditional paintings of theater scenes and written reports from theater performances, but also non-artistic subjects such as political proclamations, court protocols or court scene drawings. This property does not pertain to abstract artful expressions of impressions from the respective Activity, interpretations or representations from indirect evidence. The latter relationship between the created Expression and the respective Activity can be documented via the property P129 is about (is subject of).

Examples: (take from FRBRoo recording)

- The making of the recording of the third alternate take of the musical work entitled 'Blue Hawaii' as performed by Elvis Presley in Hollywood, Calif., Radio Recorders, on March 22nd, 1961 (F28) *Rnn included a memory of* Elvis Presley's performance of the musical work entitled 'Blue Hawaii' in Hollywood, Calif., Radio Recorders, on March 22nd, 1961 (E7)

482:

CR1 Vulnerability Assessment

CR1 Vulnerability Assessment

Subclass of: I5 Inference Making

Scope note: This class comprises making propositions and statements about vulnerability for instances of E24 Physical Human-Made Thing. These propositions are created using existing beliefs based on hypotheses and some inference logic. This class describes the process of evaluating the resilience level of an instance of E24 Physical Human-Made Thing against the damaging potential of local factors. The process that instances of CR1 Vulnerability Assessment describe takes into account the current physical features and condition of the instances of E24 Physical Human-Made Thing that it assesses. It includes evaluation, calculation, and interpretation based on mathematical formulation and propositions.

Examples:

- the vulnerability assessment of St. Peter Cathedral
- the vulnerability assessment of Gubbio historic centre in 2022

Properties

PR4 assessed vulnerability of (had vulnerability assessed by): E24 Human-Made Thing

CR2 Vulnerability Belief

CR2 Vulnerability Belief

Subclass of: I2 Belief

Scope note: This class comprises beliefs resulting from instances of CR1 Vulnerability Assessment. The instance of I4 Proposition Set, that is associated with an instance of CR2 Vulnerability Belief through property *J4 that*, describes the vulnerability of the assessed instance of E24 Physical Human Made Thing. This description could be ascribed through instances of E54 Dimension, through categorical statements or other means.

Examples:

- the belief that the vulnerability of St. Peter Cathedral is high level
- the belief that the vulnerability of Gubbio historic centre is low level in 2022

Properties

PR1 ascribed (was ascribed by): E54 Dimension

PR2 held on (had belief held by): E24 Physical Human-Made Thing

PR3 held by (held): E39 Actor

549:

TXP16 employs script -approve scope note and examples

TXP16 employs script (is employed in)

Domain: TX3 Writing System

Range: TX13 Script

Subproperty of E89 Propositional Object. P148 has component (is component of): E89 Propositional Object.

Quantification: many to many (0,n:0,n)

Scope note: This property associates an instance of TX3 Writing system with one of the instances of the TX13 Script it employs

Examples: (post editing)

- The Latin writing system used in the inscription of the Arch of Constantine (TX3) *employs script* the Latin script (TX13)
- The Oscan writing system used in the inscription of the Tabula Bantina (TX3) *employs script* the Latin script (TX13)
- The Oscan writing system used in the inscription of the Arch of Constantine (TX3) *employs script* the Greek script (TX13)

In First Order Logic:

$TXP16(x,y) \Rightarrow TX3(x)$

$TXP16(x,y) \Rightarrow TX13(y)$

$TXP16(x,y) \Rightarrow P148(x,y)$

TXP7 has item (is item of) -scope note redefinition

TXP7 has item (is item of)

Domain: TX13 Script

Range: TX8 Grapheme

Subproperty of:

Quantification: many to many (0,n:0,n)

Scope note: This property associates an instance of TX8 Grapheme with the instance of TX13 Script in which it is referred, distinct from other graphemes in it, for the purpose of using it conforming to the script. Different instances of TX13 Script may have some graphemes in common, but not all.

Examples:

- The Latin script (TX13) has item the ideal capital letter “S”

In First Order Logic:

$TXP7(x,y) \Rightarrow TX3(x)$

$TXP7(xy,) \Rightarrow TX8(y)$

TXP17 has part (forms part of) -proposed property definition

TXP17 has part (forms part of)

Domain: TX12 Grapheme Sequence

Range: TX12 Grapheme Sequence

Subproperty of P106 is composed of (forms part of)

Quantification: one to many (0,n:0,1)

Scope note: This property associates an instance of TX12 Grapheme Sequence with another instance of TX12 Grapheme Sequence appearing at a particular position of the sequence.

Note that a grapheme occurrence may be a symbolic composite containing another grapheme occurrence, such as the minute character “e” on top of the character “u” in former German writing systems denoting the symbol for “ü”.

Examples:

In First Order Logic:

$TXP16(x,y) \Rightarrow TX12(x)$

$TXP16(x,y) \Rightarrow TX11(y)$

$TXP16(x,y) \Rightarrow P148(x,y)$

TXP18 read (was read by) –proposed shortcut property definition

TXP18 read (was read by)

Domain: TX14 Reading

Range: TX1 Written Text

Subproperty of: Jxx10 interpreted meaning of (was interpreted by)

Quantification: one to many (0,n:0,1)

Scope note: This property associates an instance of TX14 Reading with an instance of TX1 Written Text, the linguistic meaning of which was interpreted through the reading process. It is a shortcut of the fully developed path P9 consists of: TX5 Text Recognition. TXP10 deciphered text: TX1 Written Text

Examples:

- The reading of the Greek text present on the Derveni papyrus (TX14) *read* the papyrus (TX1) [interpreted the linguistic meaning that was carried by it].

In First Order Logic:

$TXP16(x,y) \Rightarrow TX12(x)$

$TXP16(x,y) \Rightarrow TX11(y)$

$TXP16(x,y) \Rightarrow P148(x,y)$